

First Edition: 12 February 2019

**SERVICE MANUAL
&
PARTS LIST**

MODEL: J30

INDEX

WHAT TO DO WHEN	1-3
CHANGING EXTERNAL PARTS	
FACE COVER	4
FREE-ARM COVER	5
FRONT COVER	6
REAR COVER.....	7
MECHANICAL ADJUSTMENT	
PRESSER BAR HEIGHT	8
NEEDLE DROP POSITION.....	9
ADJUSTMENT OF HOOK TIMING	10
ADJUSTMENT OF NEEDLE BAR HEIGHT	11
CLEARANCE BETWEEN NEEDLE AND TIP OF ROTARY HOOK	12
FEED DOG HEIGHT	13
TOP TENSION	14
STRETCH STITCH FEED BALANCE	15
REPLACEMENT AND ADJUSTMENT OF THE NEEDLE THREADER PLATE.....	16
ADJUSTING BUTTONHOLE LEVER POSITION.....	17
SELF-DIAGNOSTIC TEST	
SELF-DIAGNOSTIC TEST	18-23
TO DISPLAY THE VERSION OF THE PROGRAM.....	23
REPLACING THE ELECTRONIC COMPONENTS	
PRINTED CIRCUIT BOARD A CONNECTION	24
PRINTED CIRCUIT BOARD A	25
PRINTED CIRCUIT BOARD F2	26
PRINTED CIRCUIT BOARD F1	27
PRINTED CIRCUIT BOARD L.....	28
DRIVING MOTOR (DC MOTOR)	29
SWITCHING REGULATOR UNIT.....	30
PARTS LIST	31-45

WHAT TO DO WHEN

Condition	Cause	How to fix	Reference
<p>1. Skipping Stitches</p>	<ol style="list-style-type: none"> 1. Needle is not inserted properly. 2. Needle is bent or worn. 3. Incorrectly threaded. 4. Needle or thread are inappropriate for the fabric being sewn. 5. Sewing on stretch fabric. 6. Inappropriate needle bar height. 7. Inappropriate needle to hook timing. 8. Inappropriate needle to hook clearance. 	<p>Insert the needle properly.</p> <p>Change the needle.</p> <p>Rethread.</p> <p>Use the recommended sewing needle and thread.</p> <p>Use a HA x #11 blue tip needle.</p> <p>See mechanical adjustment "Adjustment of needle bar height".</p> <p>See mechanical adjustment "Adjustment of hook timing".</p> <p>See mechanical adjustment "Clearance between needle and tip of the rotary hook".</p>	<p>P. 11</p> <p>P. 10</p> <p>P. 12</p>
<p>2. Fabric not moving</p>	<ol style="list-style-type: none"> 1. Incorrect feed dog height. 2. Feed dog is in down position. 3. Thread on bottom side of fabric is jammed up. 4. Feed dog teeth are worn. 	<p>Adjust the presser bar level to make the pressure stronger. See mechanical adjustment "Feed dog height".</p> <p>Raise the feed dog.</p> <p>Make sure to bring both needle and bobbin threads under the foot when start sewing.</p> <p>Change the feed dog.</p>	<p>P. 13</p>

Condition	Cause	How to Fix	Reference
3. Breaking upper thread.	<ol style="list-style-type: none"> 1. Initial sewing speed is too fast. 2. Thread path is incorrect. 3. Needle is bent or dull. 4. Top tension is too strong. 5. Needle size is inappropriate for fabric. 6. Needle eye is worn. 7. Needle hole in needle plate is worn or burred. 	<p>Start with medium speed.</p> <p>Use the proper thread path.</p> <p>Replace with a new needle.</p> <p>Adjust top tension correctly.</p> <p>Use appropriate needle for fabric and thread in use.</p> <p>Change the needle.</p> <p>Repair the hole or replace the needle plate.</p>	
4. Breaking bobbin thread.	<ol style="list-style-type: none"> 1. Bobbin holder is incorrectly threaded. 2. Too much thread is wound on the bobbin. 3. Lint is stuck inside the bobbin holder. 4. Thread quality is too low. 5. Thread is jamming around the bobbin holder. 	<p>Set the bobbin thread correctly.</p> <p>Adjust the position of bobbin winder stopper.</p> <p>Clean the bobbin holder.</p> <p>Change to a high quality sewing thread.</p> <p>Clear out the jamming thread.</p>	
5. Needle breaks	<ol style="list-style-type: none"> 1. Needle is hitting the needle plate. 2. Needle is bent or worn. 3. Needle is hitting the hook. 4. Fabric is being pulled too strongly while sewing. 	<p>See mechanical adjustment "Needle drop position".</p> <p>Change the needle.</p> <p>See mechanical adjustment "Clearance between needle and tip of the rotary hook".</p> <p>Guide the fabric gently while sewing.</p>	<p>P. 9</p> <p>P. 12</p>

Condition	Cause	How to fix	Reference
6. Noisy operation	<ol style="list-style-type: none"> 1. Backlash between hook gear and lower shaft gear is too great. 2. Lower shaft gear is loose. 3. Inappropriate belt tension. 4. Not enough oil. 5. Upper shaft gear is loose. 	<p>Eliminate the backlash.</p> <p>Eliminate the looseness.</p> <p>See part removal and replacement “driving motor (DC motor)”.</p> <p>Oil all moving parts.</p> <p>Eliminate the looseness.</p>	P. 29
7. Deformation pattern	<ol style="list-style-type: none"> 1. Inappropriate feed balance. 2. Top tension is too strong. 	<p>Adjust the feed balancing screw.</p> <p>See mechanical adjustment “Top tension”.</p>	<p>P. 15</p> <p>P. 14</p>

CHANGING EXTERNAL PARTS

FACE COVER

To remove:

1. Remove the cap and setscrew ① and lift the face cover to disengage the rib on the inside.
Remove the face cover ②.

To attach:

2. Follow the above procedures in reverse.

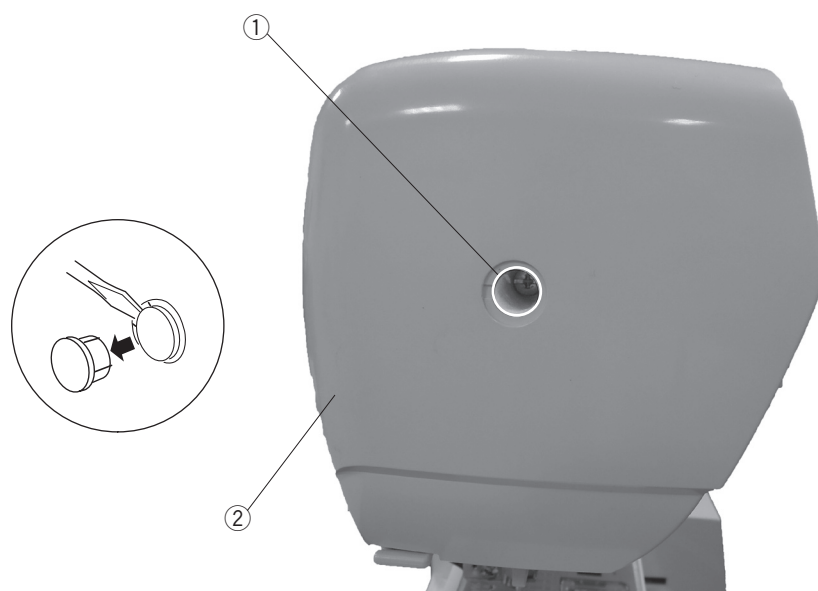

CHANGING EXTERNAL PARTS

FREE-ARM COVER

To remove:

1. Remove the setscrew ① and ②.
Move the free-arm cover ③ to the left.
Remove the free-arm cover.

To attach:

Follow the above procedures in reverse.

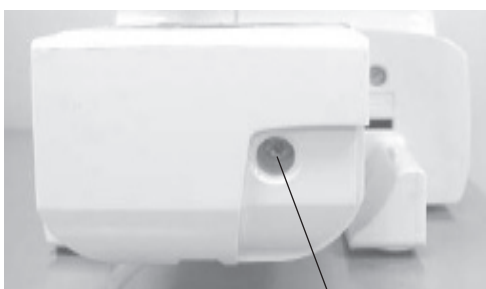

①

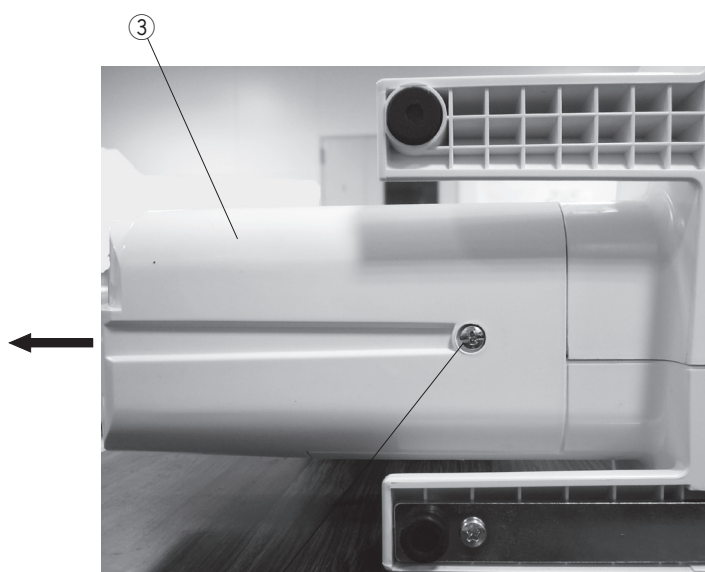

②

CHANGING EXTERNAL PARTS

FRONT COVER

To remove:

1. Remove the face cover and free-arm cover (See page 4 and 5).
2. Remove the setscrews ① (2 pcs.).
3. Remove the setscrews ② (4 pcs.), back cover ③.
4. Remove the setscrews ④ (2 pcs.).
5. Loosen the setscrew ⑤.
6. Disengage the front cover and rear cover hooks.
7. Remove the front cover.
8. Disconnect all the connectors from the circuit board A.

NOTE:

Do not disconnect the connectors by pulling on cord. To disconnect, grasp the connector, not the cord.

To attach:

7. Follow the above procedures in reverse. See "PRINTED CIRCUIT BOARD A CONNECTION". (Page 24)

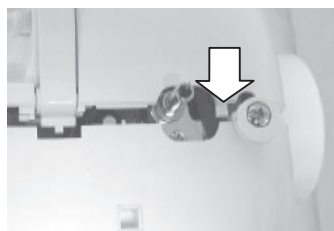
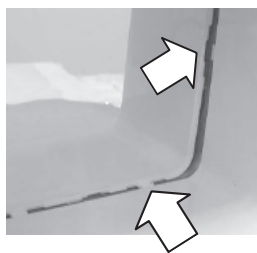
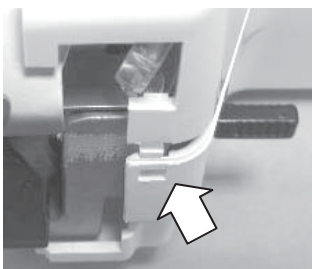
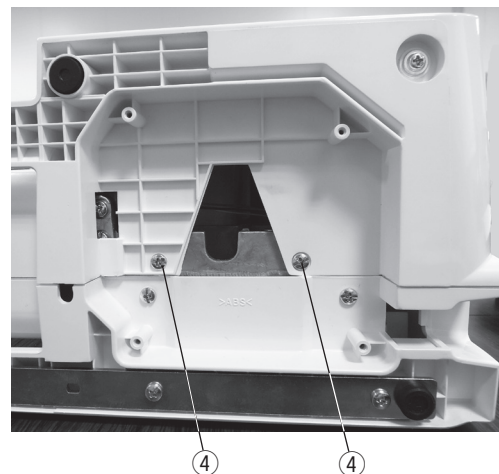
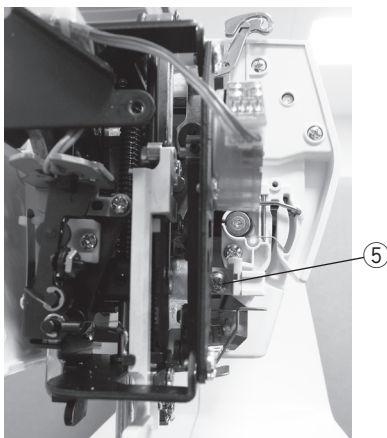
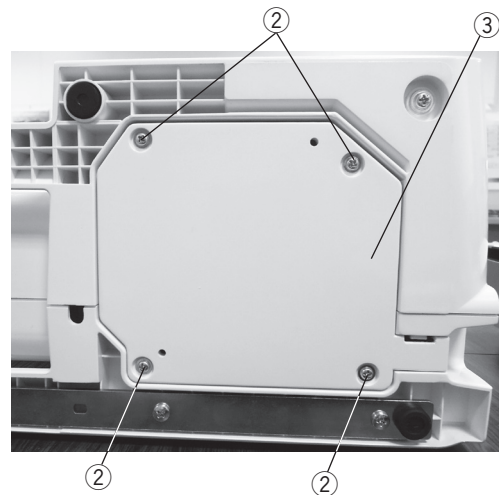
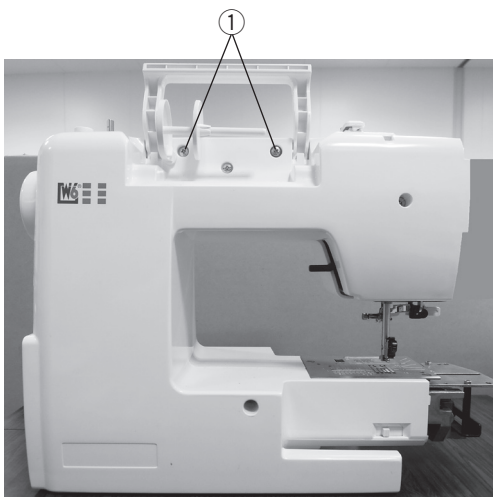

CHANGING EXTERNAL PARTS

REAR COVER

To remove:

1. Remove the face cover and free-arm cover (See page 4 and 5).
2. Remove the setscrews ① (2 pcs.) and the setscrews ② (3 pcs.).
3. Remove the setscrews ③ (4 pcs.) and back cover ④.
4. Remove the setscrews ⑤ (2 pcs.).
6. Disengage the front cover and rear cover hooks.
7. Remove the front cover.

To attach:

5. Follow the above procedures in reverse.

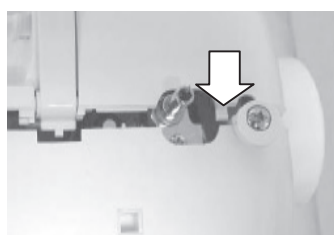
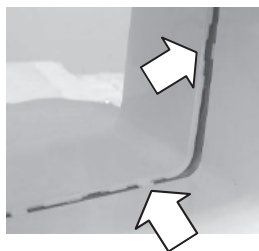
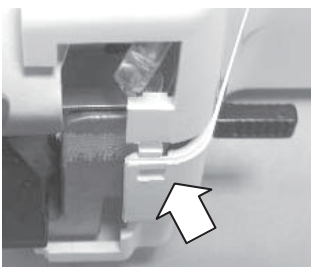
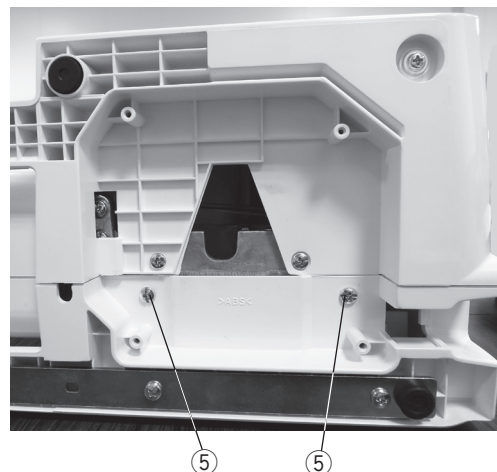
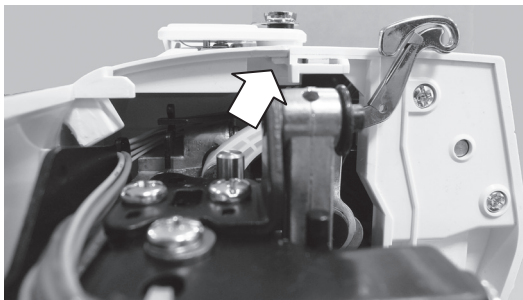
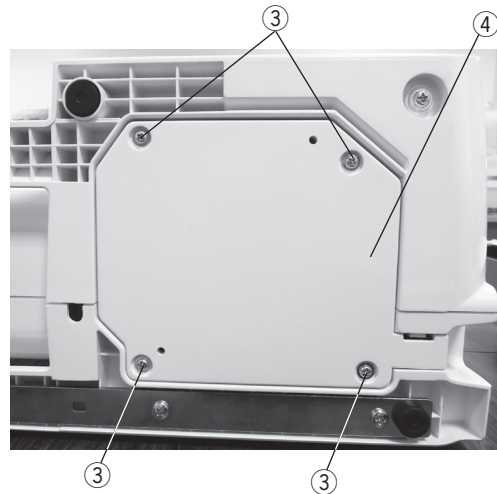

MECHANICAL ADJUSTMENT

PRESSER BAR HEIGHT

The distance between the bottom of the presser foot in up position and the needle plate should be 6.0 mm.

1. Remove the face plate and needle.
2. Lower the feed dog below the needle plate.
Place a block 6 mm thick under the presser foot and lower the presser foot lifter ②.
3. Loosen the setscrew ①. Raise the presser foot lifter and tighten the setscrew ① firmly.
Attach the needle and face plate.

NOTE:

Make sure that the presser foot should be parallel to the feed dog slots in the needle plate.

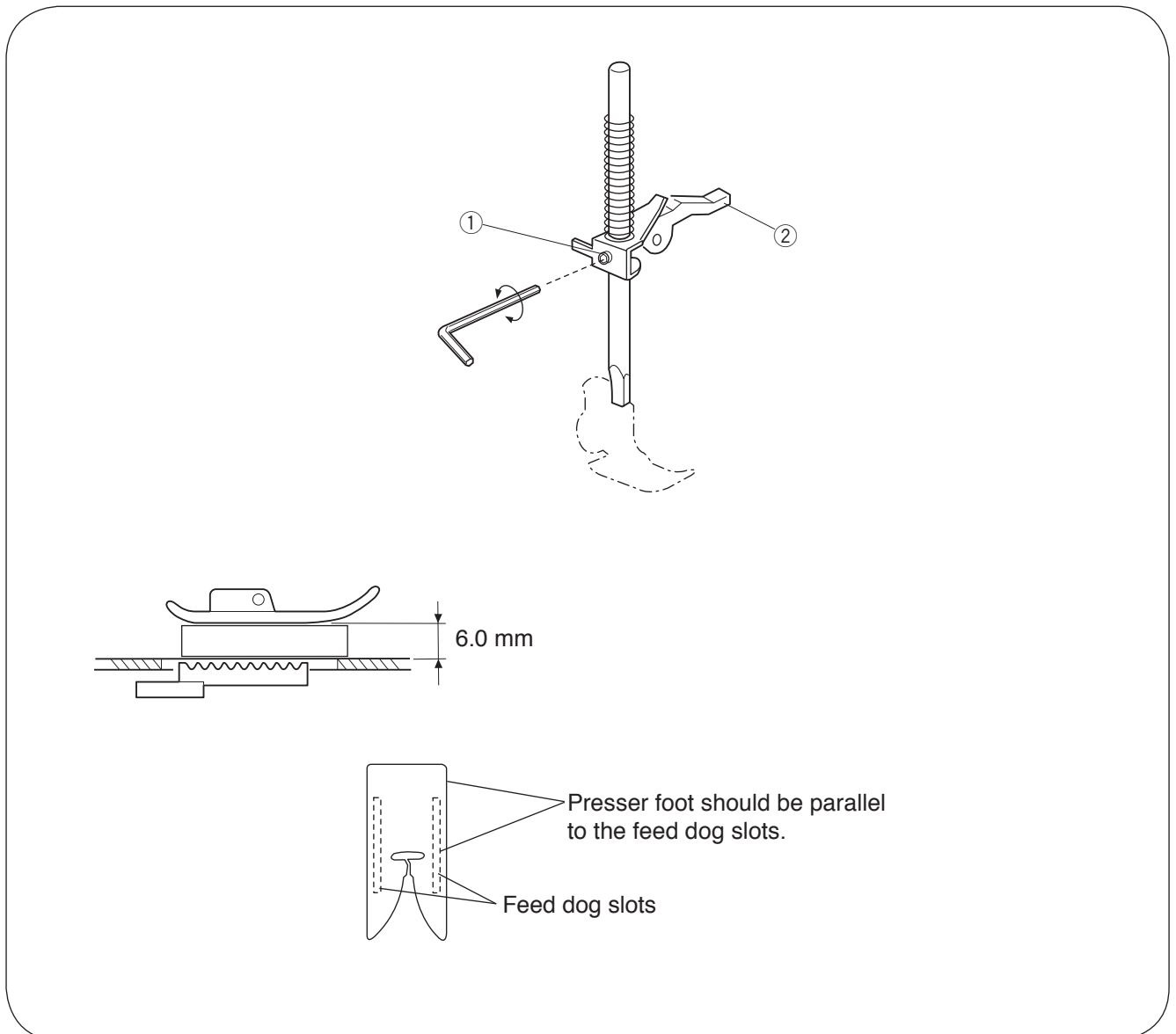

MECHANICAL ADJUSTMENT

NEEDLE DROP POSITION

Set the stitch pattern to “ \oplus ”. The standard needle drop position should be at center of the needle plate hole. Select zigzag stitch “ \sim ”, and set the stitch width at “7.0”. The clearance between the needle and the edge of the needle hole should be at least 0.2 mm on either side. If not, adjust as follows:

1. Turn the power switch off. Remove the face cover. (See page 4.)
2. Loosen the hexagonal socket screw 3 x 4 ①. Adjust the needle drop position by turning the eccentric pin. The direction of eccentric pin should be as shown in Fig. 1.
3. Attach the face cover.

NOTE:

Check the hook timing after this adjustment.

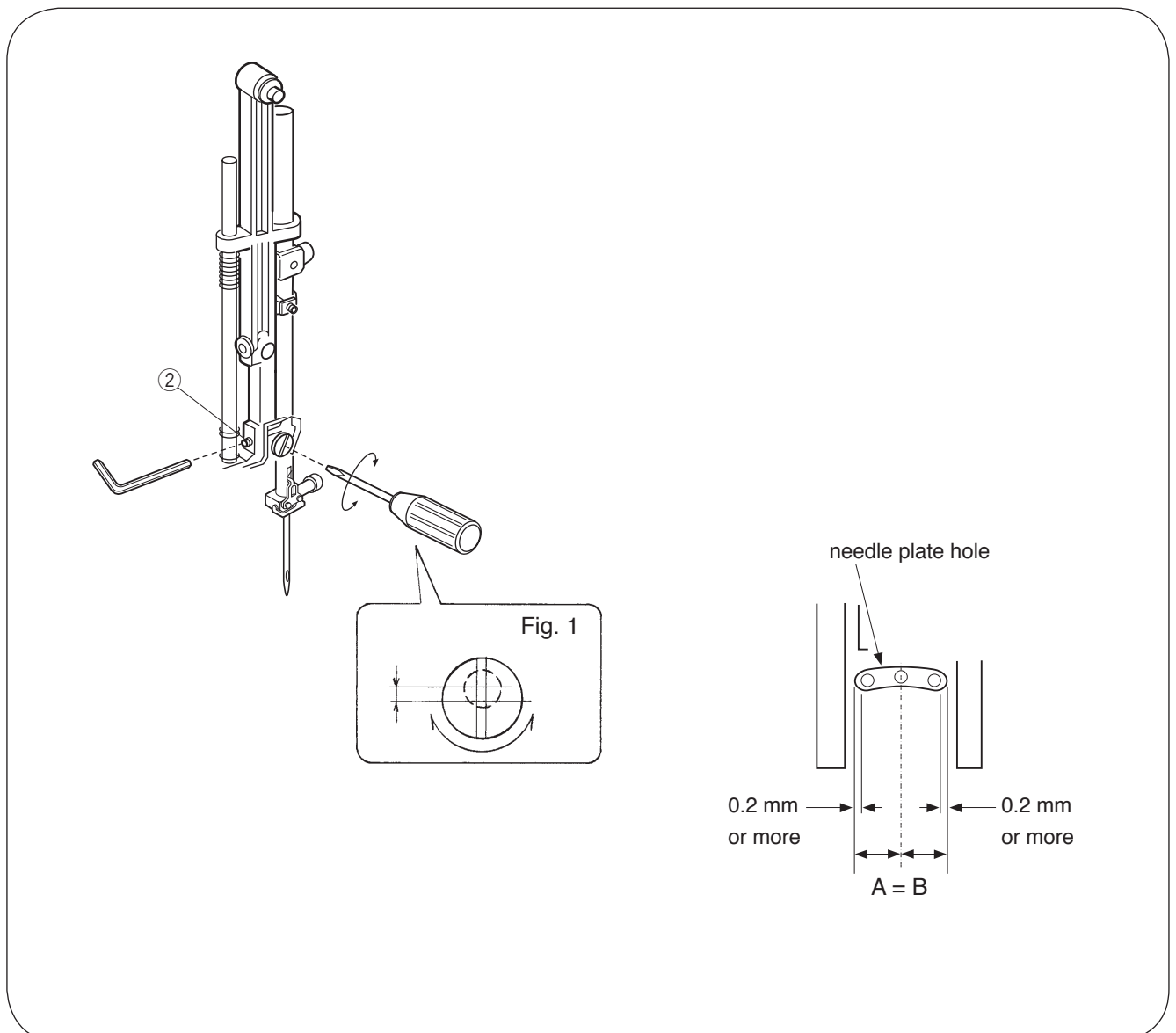

MECHANICAL ADJUSTMENT

ADJUSTMENT OF HOOK TIMING

The amount of ascending travel of the needle bar from its lowest position to the position () where the tip of the rotary hook exactly meets the right side of the needle should be 3.25 to 3.55 mm.

1. Remove the needle plate and bobbin holder.
2. Turn the power switch on.
3. Select the pattern  (left position). Set the zigzag width at 0.
4. Remove the free-arm cover. (See page 5.)
Turn the handwheel toward you to lower the needle at its lowest position.
5. Loosen the hexagonal socket screw ② (2 pcs.).
6. Move the needle bar 3.4 mm from the lowest position.
7. Turn the lower shaft gear until the tip of hook meets the right side of the needle while holding the handwheel.
8. Tighten the hexagonal socket screw ② (2 pcs.).
9. Attach the free-arm cover, bobbin holder and needle plate.

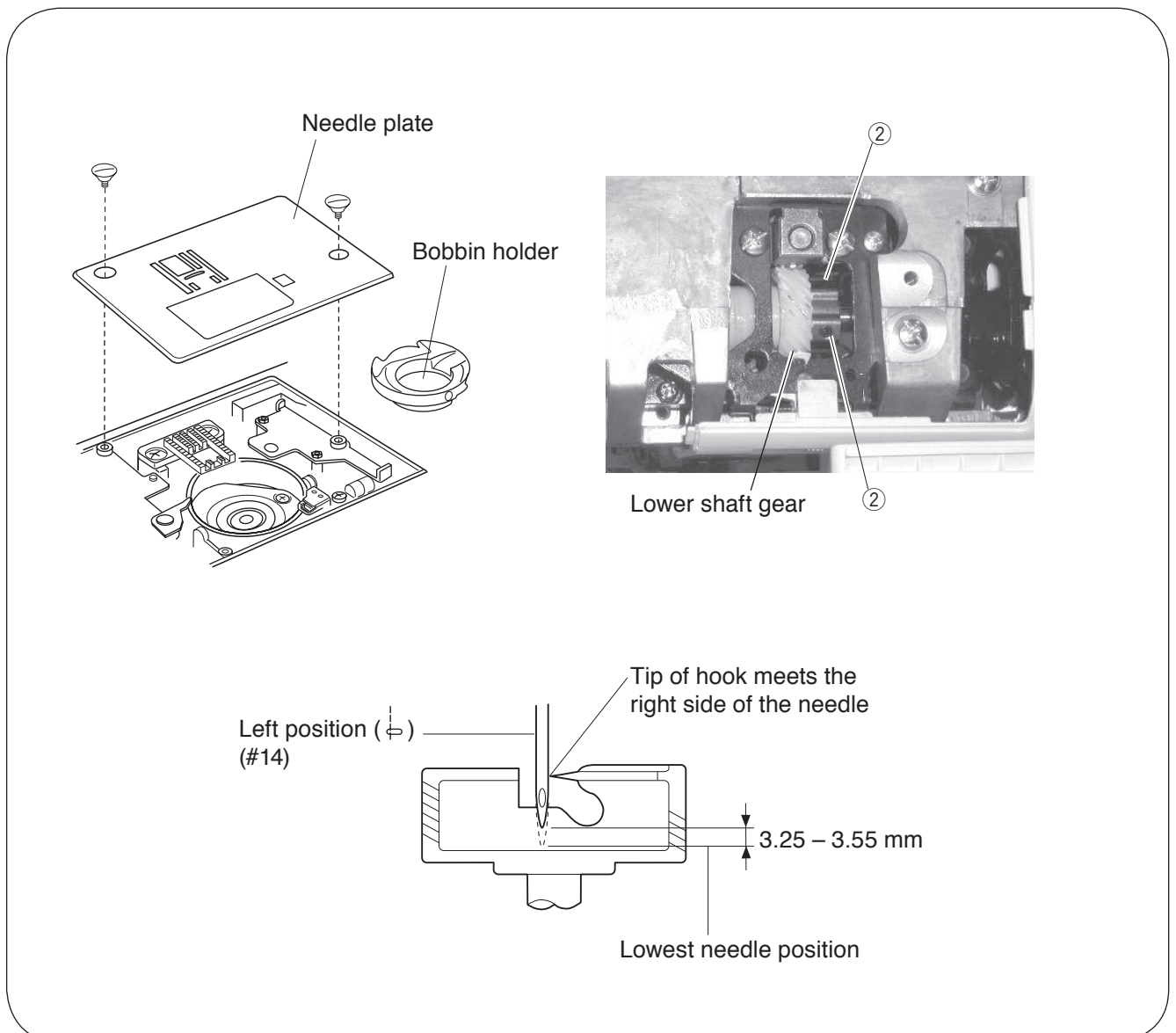

MECHANICAL ADJUSTMENT

ADJUSTMENT OF NEEDLE BAR HEIGHT

Before proceeding with this adjustment, check the hook timing (refer to page 10). The distance between the upper edge of the needle eye and the tip of the hook should be in the range of 1.6 to 2.0 mm when the tip of the hook timing meets right side of the needle in the left needle position () as the needle ascends from its lowest position.

1. Remove the needle plate, bobbin holder and face plate.
2. Turn the power switch on.
3. Select the pattern  (left position). Set the zigzag width at 0.
4. Turn the handwheel toward you until the tip of hook meets the right side of the needle.
5. Loosen the hexagonal socket screw ①.
6. Move the needle bar to adjust the needle bar height, and tighten the hexagonal socket screw ①.
Be careful not to turn the needle bar.
7. Attach the bobbin holder, needle plate and face cover.

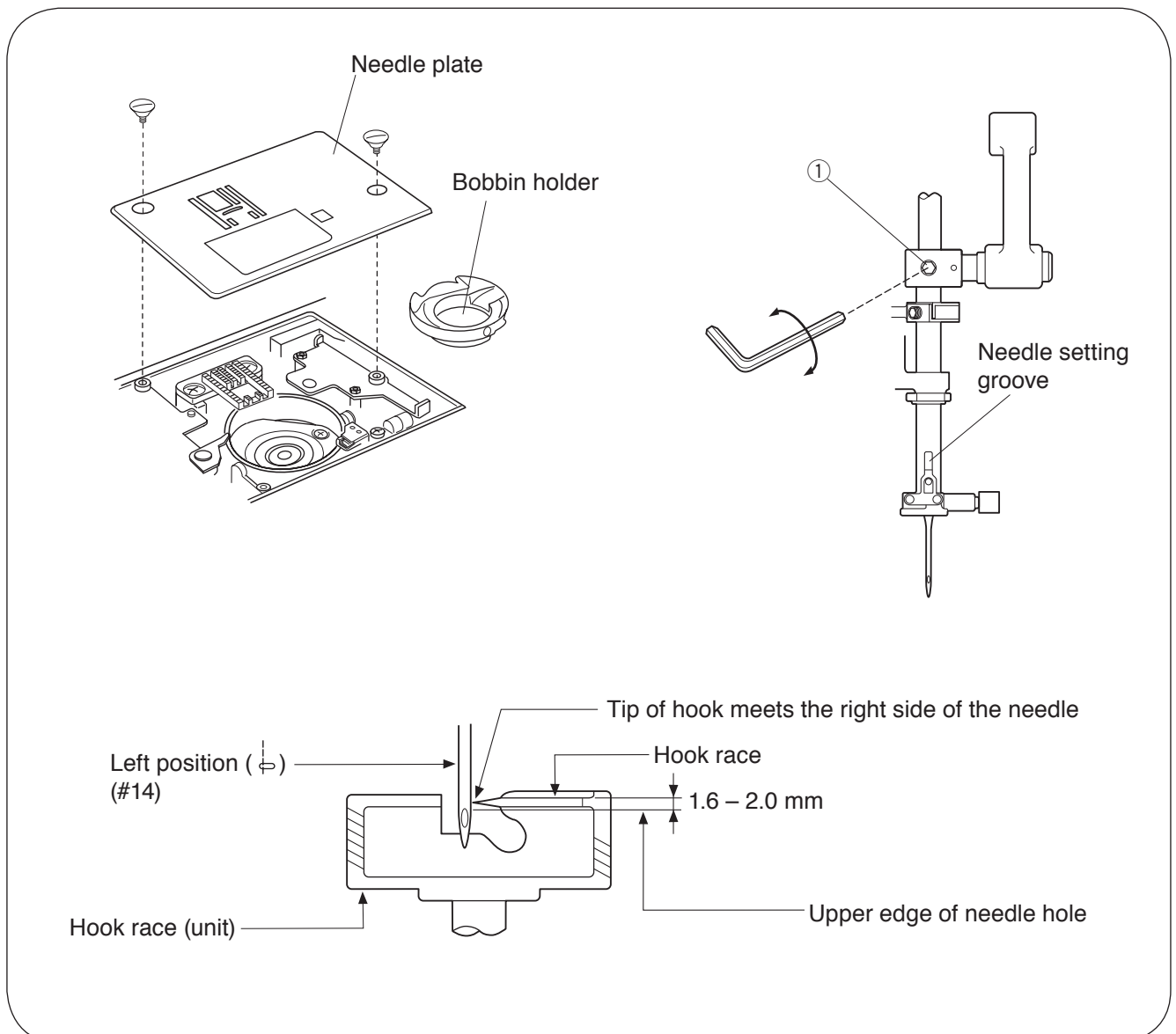

MECHANICAL ADJUSTMENT

CLEARANCE BETWEEN NEEDLE AND TIP OF THE ROTARY HOOK

* The clearance between the needle and the point of hook should be -0.1 to $+0.05$ mm.

Adjustment procedure:

1. Remove the needle plate and bobbin holder. Attach the master needle. Turn the power switch on and set the zigzag width at maximum.
2. Remove the face cover. (See page 4.)
3. Loosen the setscrews ① (2 pcs.).
4. Turn the handwheel toward you. Adjust the clearance between the needle and the tip of the rotary hook, by moving the hook base plate up or down, to within -0.1 to $+0.05$ mm at the left and right needle position.
5. Tighten the setscrews ① (2 pcs.).
6. Attach the face cover. Remove the master needle. Attach the bobbin holder and needle pate.
7. Check the clearance between the needle and the edge of the needle hole in the needle plate (see page 9).

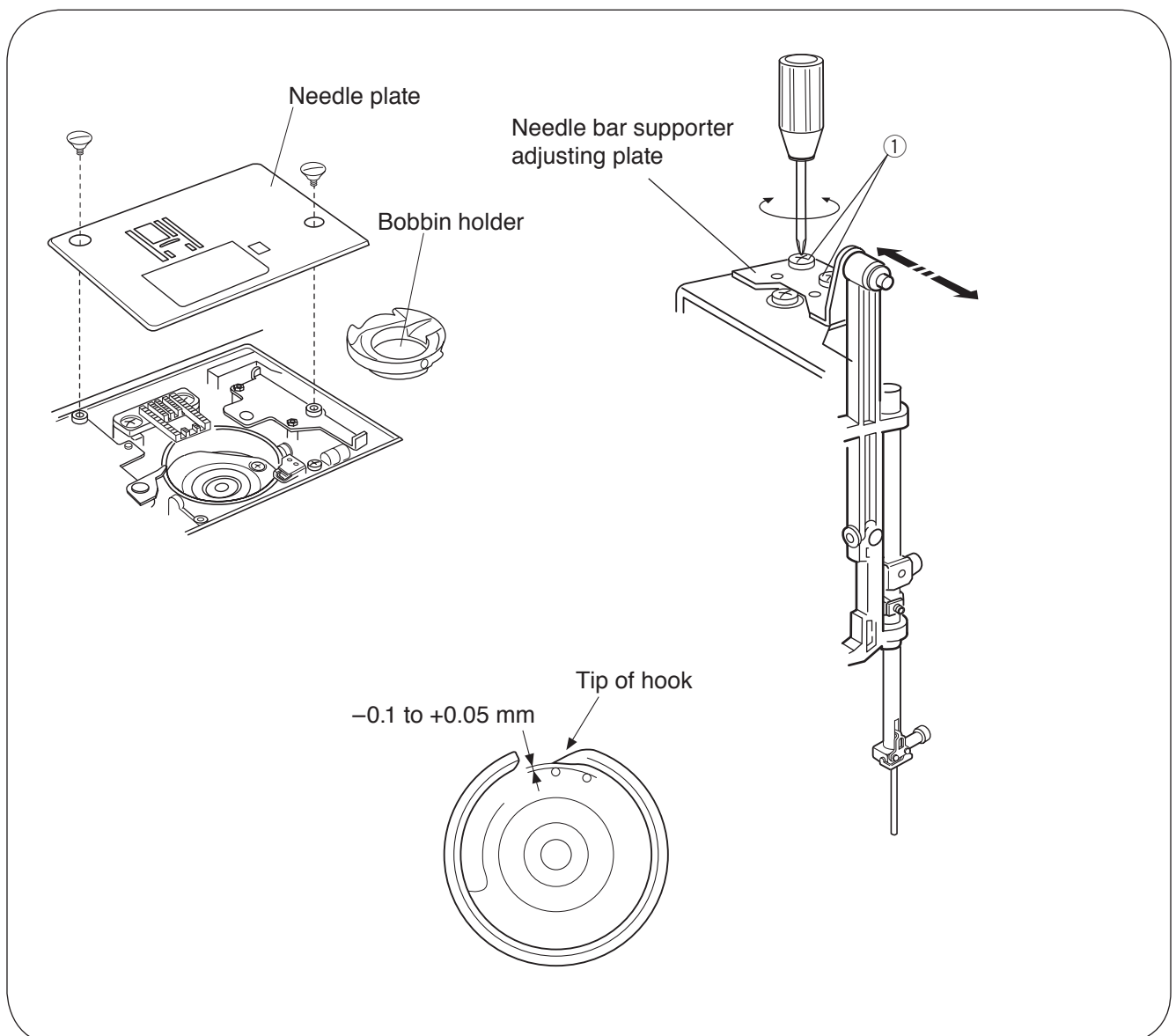

MECHANICAL ADJUSTMENT

FEED DOG HEIGHT

The highest position of the feed dog should be between 0.80 and 0.90 mm from the surface of the needle plate.

1. Lower the presser foot and turn the power switch on.
2. Turn the handwheel toward you to set the feed dog at the highest position.
3. Remove the free-arm cover. (See page 5.)
4. Loosen the setscrew ① and nut ②.
5. Adjust the feed dog height by turning the adjusting screw ③.

The highest position of the feed dog should be between 0.80 and 0.90 from the surface of the needle plate.

6. Tighten the nut ② and setscrew ①.
7. Attach the free-arm cover.

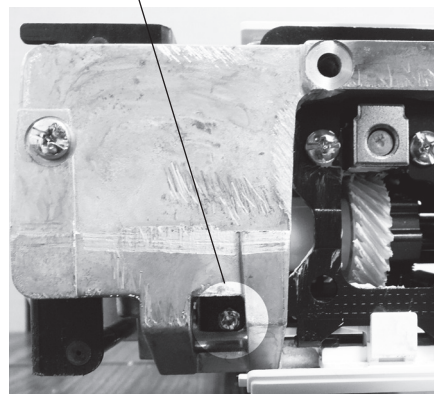
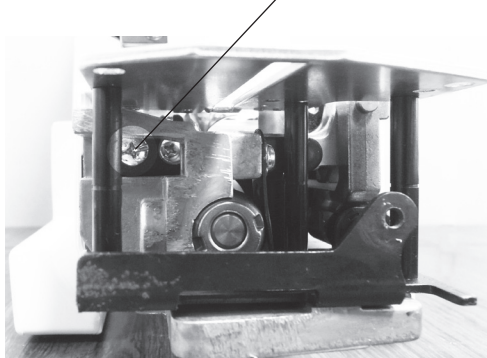
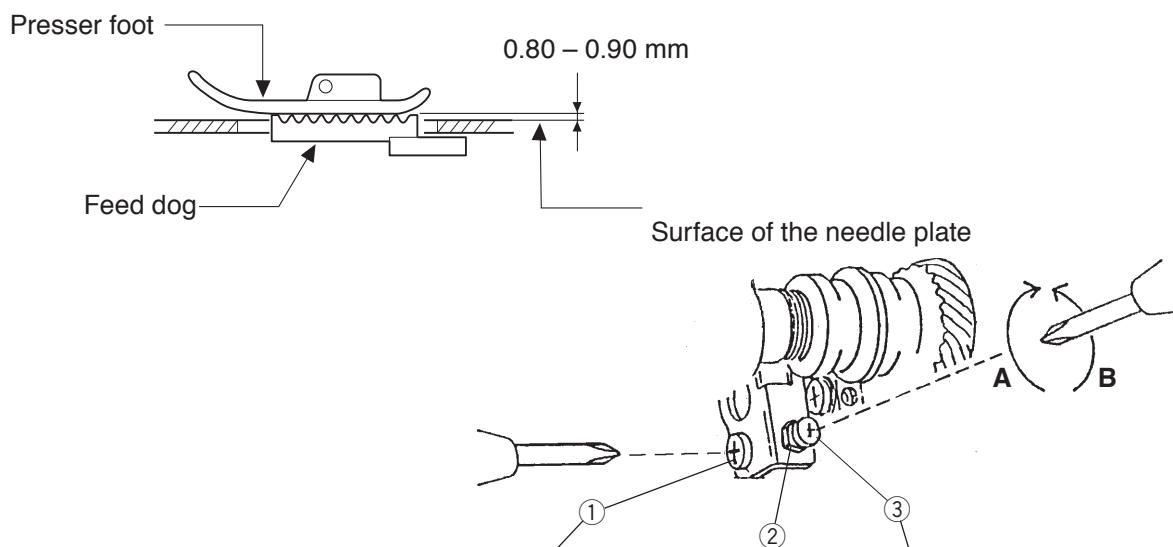

MECHANICAL ADJUSTMENT

TOP TENSION

The top tension should be between 65 and 80 g when pulling the thread up in the direction of arrow.

* Use polyester sewing thread #50 (White).

* If it is not within the above limit, adjust as follows.

1. Set the tension dial "4".
2. Remove the face cover and front cover. (See page 4 and 6.)
3. Lower the presser foot.
 - If the top tension is too loose, turn the lead screw in the direction (A).
 - If the top tension is too tight, turn the lead screw in the direction (B).
4. Check the top tension and attach the cover.

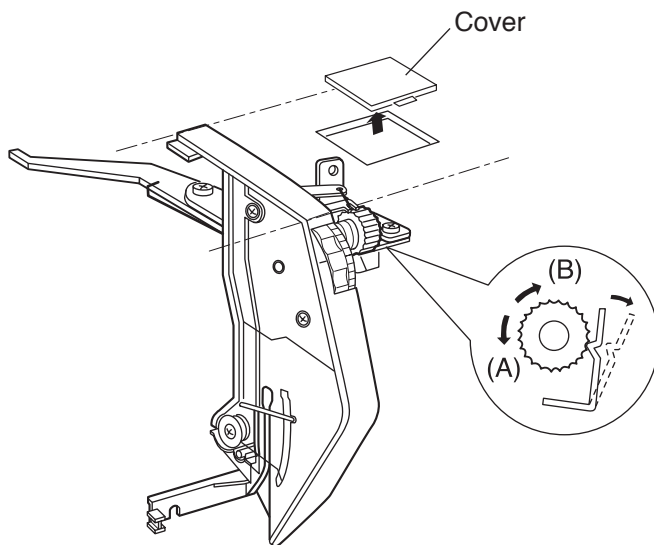

Pull the thread at the speed of 110 mm/sec in the direction of arrow

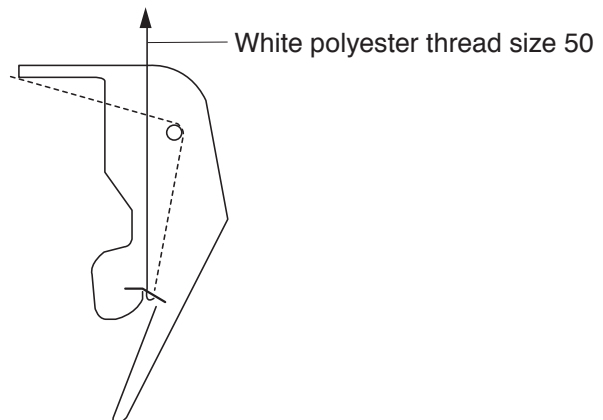

MECHANICAL ADJUSTMENT

STRETCH STITCH FEED BALANCE

To check:

1. Enter the self-diagnostic mode (see below).
Attach the Satin stitch foot F. Place a fabric under the presser foot. Lower the presser foot.
2. Press the locking stitch button to start test sew, and check the results (the standard figure length of 5 pieces of figure 8 is 33-39 mm).
3. If stretch patterns are distorted, correct them with the feed balancing dial.
If stretch patterns are too deformed and cannot be corrected with the feed balancing dial, adjust as follows.

To adjust:

1. Remove the feed balancing dial cover. Turn the dial at standard position as illustrated.
Turn the power switch ON.
Select the straight stitch and set the stitch length at "0". Place a fabric under the presser foot.
Lower the presser foot. (Do not set bobbin and needle threads)
2. Turn the hexagonal socket screw to the left to loosen it.
Move the gear up (A) or down (B) to adjust the feed.
* Do not move the gear right or left when adjusting.
Start the machine and check the movement of the fabric.
Adjust the hexagonal socket screw position (gear position) until the fabric will not be fed with the stitch length setting at "0".
3. Tighten the socket screw and attach the feed balancing dial cover.
Enter the self-diagnostic mode and test sew again. Check that the standard length of 5 pieces of figure 8 is 33-39 mm. If not, turn the feed balancing dial to correct it.

TO ENTER SELF-DIAGNOSTIC MODE:

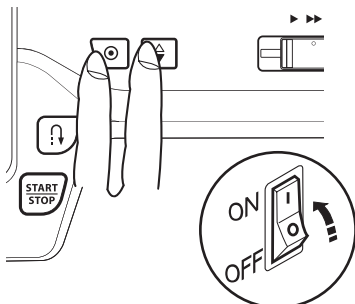

Turn the power switch on while simultaneously pressing auto-lock button and needle up/down button.

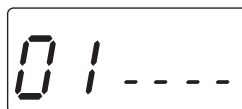

The LCD display will indicate "01".



Press the value set key 7 times to display the "08".

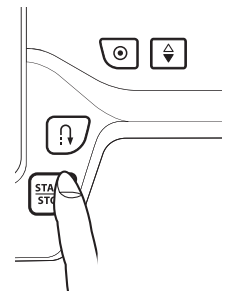

Press the start/stop button to display the "88" and to enter the stretch stitch test mode.

Incorrect Correct Incorrect

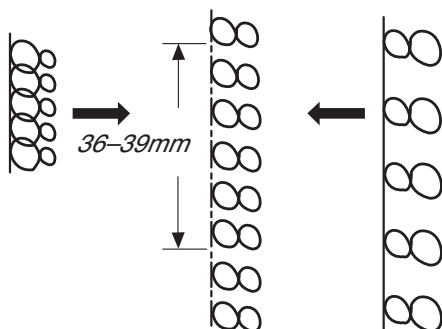

The standard figure length of 5 pieces of figure 8 is 33-39 mm

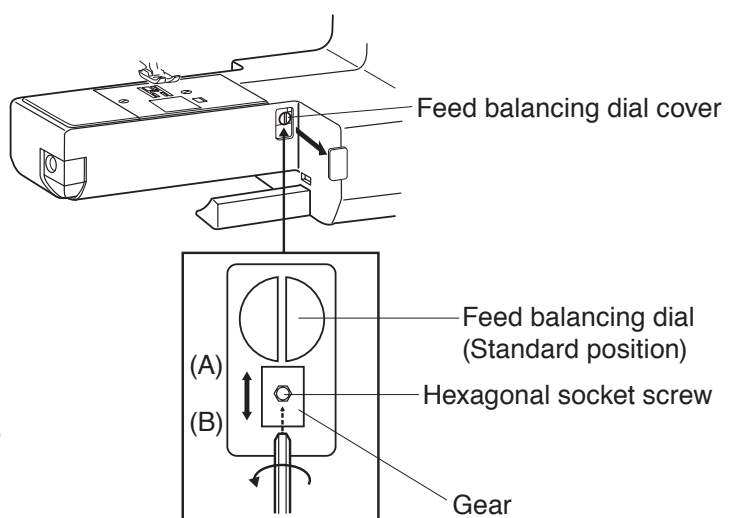

MECHANICAL ADJUSTMENT

REPLACEMENT AND ADJUSTMENT OF THE NEEDLE THREADER PLATE

If the hook of the threader plate is damaged, change and adjust the part as follows:

TO CHANGE THE THREADER PLATE:

1. Push down the needle threader knob and pull the threader plate supporter down to remove it (see FIG 1).
2. To install the needle threader plate, line the groove up with the pin and push it up to snap fit.

TO ADJUST THE THREADER PLATE POSITION:

1. If the hook on the threader positioning plate touches the top or bottom side of the needle hole, loosen setscrew ① and adjust the hook position (FIG.2).
2. If the hook on the threader plate touches the left or right side of the needle hole, loosen setscrew ② and adjust the hook position (FIG 3).

Replacing the threader plate supporter
(with the threader plate attached)

FIG. 1

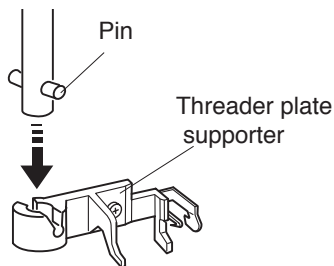

Vertical adjustment

FIG. 2

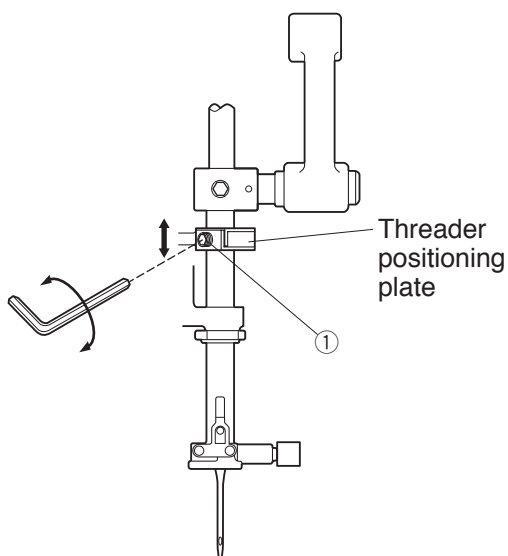

Adjustment of left or right direction

FIG. 3

View from "X"

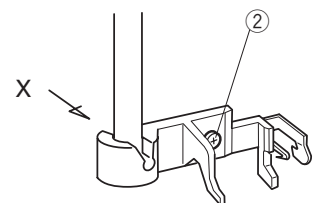
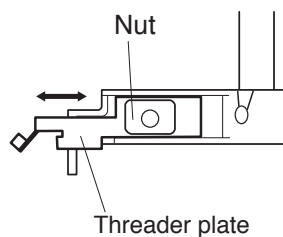

MECHANICAL ADJUSTMENT

ADJUSTING BUTTONHOLE LEVER POSITION

TO ADJUST THE BUTTONHOLE LEVER GUIDE:

1. Enter the diagnostic test of buttonhole sensor mode. (See pages 18 and 19. The LCD should display 03 and BH symbol.)
2. Remove the face cover (see page 4) and loosen the setscrew ①.
3. Move the buttonhole lever guide so the BH symbol disappears when the buttonhole lever is lowered. Tighten the setscrew.

TO ADJUST THE BUTTONHOLE SENSOR POSITION:

4. Attach the buttonhole foot (R).
5. Lower the buttonhole lever to its lowest position and open a 1.6 mm gap between the slider and the buttonhole foot.
6. Turn the adjusting screw ② to the left until the LCD display BH symbol.
7. Next, turn the adjusting screw to the right until the BH symbol disappears.
8. Turn off the power switch.
9. Attach the face cover.

NOTE:

If there is any lint or dust in the buttonhole sensor slit, loosen the screw ③ and clean it out with a swab.

TO ENTER ADJUSTING MODE

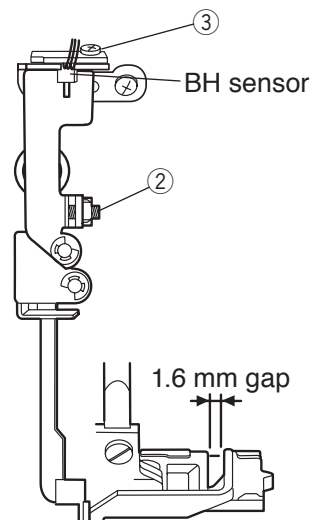
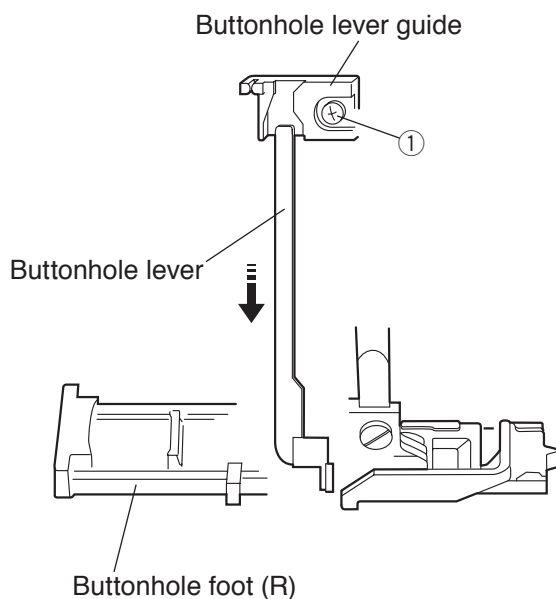
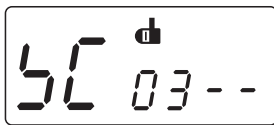

SELF-DIAGNOSTIC TEST

Preparation:

1. Turn the power switch off.
2. Move the bobbin winder spindle to the left.
3. Raise the feed dog.
4. Set the speed control lever to the left.
5. Remove the presser foot and raise the presser foot lifter.
6. Turn the hand wheel toward you to raise the needle to its highest position.

NOTE:

- Be careful: the sewing machine may start running in its own while in test mode.
 - Turn off the power switch before replacing any parts.
 - Repeat the diagnostic test until the problem has been resolved.
 - You can skip steps in the diagnostic procedure and go directly to the test you want to perform.
- (Enter self-diagnostic mode, then select the step number of the diagnostic test you require by pressing the start/stop button.)

To begin:

Turn on the switch. If any of the following problems occur, take the recommended actions in the order they are shown.

1. The machine does not respond when the power switch is turned on:
 - Check each connector connection
 - Replace the machine socket
 - Replace the switching regulator
 - Replace the printed circuit board A
2. The sewing machine lamp does not light up:
 - Replace the light bulb
 - Replace the printed circuit board A

TO ENTER SELF-DIAGNOSTIC MODE:

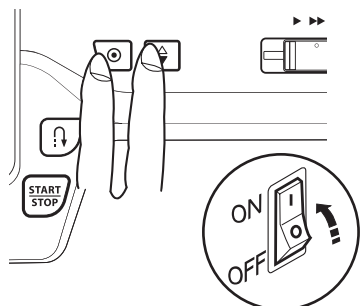

1. Turn the power switch on while simultaneously pressing auto-lock button and needle up/down button.

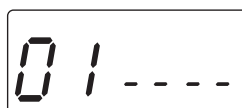

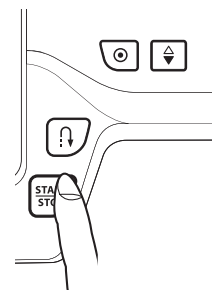

2. The LCD display will indicate "01".





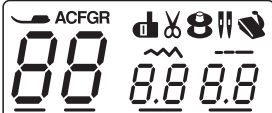
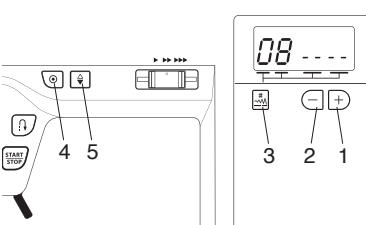

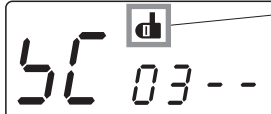
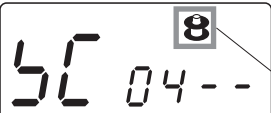
3. Press the start/stop button to enter the self-diagnostic mode.



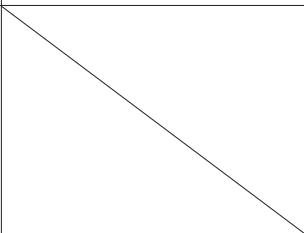

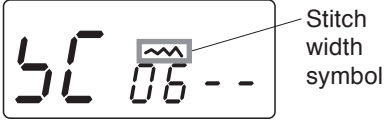
SELF-DIAGNOSTIC TEST

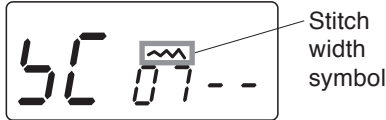
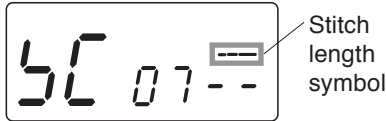
STEP AND ITEMS TO CHECK	PROCEDURE	CORRECT CONDITION	DEFECTIVE CONDITION
<p>01) FUNCTION OF LCD, BUZZER AND LAMP</p>	<p>Turn on the power switch while simultaneously pressing the auto-lock button and needle up/down button.</p> <p>Press the start/stop button to enter the self-diagnostic mode.</p> <p>If the result is correct condition, press the start/stop button to proceed the next step.</p> <p>If the result is defective condition, press the reverse stitch button to proceed the next step.</p>	<p>Sewing lamp and LCD backlight lit. LCD displays "01 ----".</p>  <p>Buzzer sounds. LCD displays symbols and numbers and blinks.</p> 	<p>Sewing lamp does not lit. LCD backlight does not lit. LCD does not display. Buzzer does not sound. LCD does not turned on. LCD does not display any symbols or not in order.</p> <p>–REMEDY– Replace the circuit board A. Replace the circuit board L.</p>
<p>02) BUTTON</p>	 <p>Press buttons 1– 5.</p> <p>If the result is correct condition, press the start/stop button to proceed the next step.</p> <p>If the result is defective condition, press the reverse stitch button to proceed the next step.</p>	<p>LCD displays "SC 02--".</p> <p>Buzzer sounds when button is pressed. Button number is displayed when the button is pressed.</p>  <p>LCD DISPLAYS "S3" WHEN BUTTON 1 IS PRESSED. LCD DISPLAYS "S4" WHEN BUTTON 2 IS PRESSED. LCD DISPLAYS "S6" WHEN BUTTON 3 IS PRESSED.</p>	<p>Buzzer does not sound. LCD does not display the number correctly.</p> <p>–REMEDY– Replace the circuit board A. Replace the circuit board F2.</p>
<p>03) BUTTONHOLE SENSOR</p>	<p>Lower the buttonhole lever. Move the buttonhole lever back and forth.</p> <p>If the result is correct condition, press the start/stop button to proceed the next step.</p> <p>If the result is defective condition, press the reverse stitch button to proceed the next step.</p>	<p>LCD DISPLAYS "S8" WHEN BUTTON 4 IS PRESSED. LCD DISPLAYS "S9" WHEN BUTTON 5 IS PRESSED. LCD displays "SC 03--".</p>  <p>When the buttonhole lever is pulled, buzzer sounds and LCD displays BH symbol.</p>	<p>Buzzer does not sound. BH symbol does not appear.</p> <p>–REMEDY– Adjust the BH lever sensor position. Replace the BH lever sensor. Replace the circuit board A.</p>
<p>04) BOBBIN WINDER SWITCH</p>	<p>Move the bobbin winder spindle to the right. Return it to the left.</p> <p>If the result is correct condition, press the start/stop button to proceed the next step.</p> <p>If the result is defective condition, press the reverse stitch button to proceed the next step.</p>	<p>When the buttonhole lever is pushed, buzzer sounds and LCD displays BH symbol. LCD displays "SC 04--".</p> <p>When the bobbin winder spindle is moved to the right, buzzer sounds and LCD displays the bobbin symbol.</p>  <p>When the bobbin winder spindle is moved to the left, buzzer sounds and bobbin symbol disappear.</p>	<p>Buzzer does not sound. Bobbin symbol is not displayed.</p> <p>–REMEDY– Adjust the bobbin winder switch position. Replace the bobbin winder switch. Replace the circuit board A.</p>

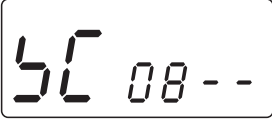

SELF-DIAGNOSTIC TEST

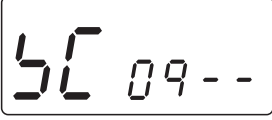
STEP AND ITEMS TO CHECK	PROCEDURE	CORRECT CONDITION	DEFECTIVE CONDITION
05) PRESSER FOOT LIFTER SWITCH	Not applicable for this machine. Press the start/stop button to proceed the next step.	LCD displays "SC 05--" and presser foot symbol.  Presser foot symbol	
06) UPPER SHAFT POSITIONING SENSOR	Turn the handwheel toward you. Lower the needle bar from its highest to lowest position. Raise the needle bar from its lowest position to highest position. If the result is correct condition, press the start/stop button to proceed the next step. If the result is defective condition, press the reverse stitch button to proceed the next step.	LCD displays "SC 06--".  Turn the handwheel. LCD displays stitch width symbol when the needle bar is at zigzag phase.  LCD displays stitch length symbol when the needle bar is at feed phase. 	Buzzer does not sound. Stitch width or length symbol does not appear. –REMEDY– Replace the circuit board P. Replace the circuit board A.
07) ZIGZAG MOTOR (STEP MOTOR) AND FEED MOTOR	Turn the handwheel toward you. Lower the needle bar its highest to position (zigzag phase). Press the needle up/down button. Raise the needle bar from its lowest position to its highest position (feed phase). Press the needle up/down button. If the result is correct condition, press the start/stop button to proceed the next step. If the result is defective condition, press the reverse stitch button to proceed the next step.	LCD displays "SC 07--".  Press the needle up/down button when LCD displays stitch width symbol. The Zigzag motor will be initialized and get its default position.  Press the needle up/down button when LCD displays stitch length symbol. The feed motor will be initialized and get its default position.	Zigzag motor does not get default position. buzzer does not sound. –REMEDY– Replace the zigzag motor. Replace the circuit board A. Feed motor does not get default position. buzzer does not sound. –REMEDY– Replace the feed motor. Replace the circuit board A.

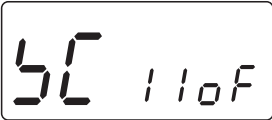
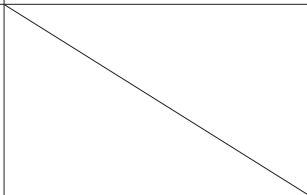
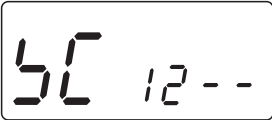
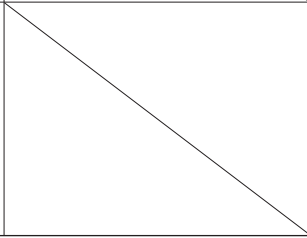
SELF-DIAGNOSTIC TEST

STEP AND ITEMS TO CHECK	PROCEDURE	CORRECT CONDITION	DEFECTIVE CONDITION
08) FOOT CONTROL	<p>Attach the foot control to the machine.</p> <p>Depress the foot control as far as it goes, then release it.</p> <p>If the result is correct condition, press the start/stop button to proceed the next step.</p> <p>If the result is defective condition, press the reverse stitch button to proceed the next step.</p>	<p>LCD displays "SC 08--".</p>  <p>The foot control symbol appears when the foot control is attached.</p>  <p>Foot control symbol</p> <p>Buzzer sounds when the foot control is deeply depressed.</p> <p>Buzzer sounds when the foot control is released.</p>	<p>The foot control symbol does not appear.</p> <p>Buzzer does not sound.</p> <p>–REMEDY–</p> <p>Replace the foot control.</p> <p>Replace the machine socket (foot control socket).</p> <p>Replace the circuit board A.</p>
09) SLIDE VOLUME	<p>Shift the slide volume from left to right, then return to the left.</p> <p>If the result is correct condition, press the start/stop button to proceed the next step.</p> <p>If the result is defective condition, press the reverse stitch button to proceed the next step.</p>	<p>LCD displays "SC 09--".</p>  <p>Buzzer sounds at rightmost or leftmost position.</p>	<p>Buzzer does not sound.</p> <p>–REMEDY–</p> <p>Replace the slide volume.</p> <p>Replace the circuit board A.</p>
10) DC MOTOR	<p>Press the needle up/down button.</p> <p>If the result is correct condition, press the start/stop button to proceed the next step.</p> <p>If the result is defective condition, press the reverse stitch button to proceed the next step.</p>	<p>LCD displays "SC 10--".</p>  <p>Machine runs slow, then fast, and the needle bar stops at its highest position.</p>	<p>The machine motor does not start.</p> <p>The motor stops immediately.</p> <p>The motor runs unstable.</p> <p>–REMEDY–</p> <p>Replace the DC motor.</p> <p>Replace the circuit board A.</p>
11) THREAD TENSION RELEASE SOLENOID	<p>Not applicable for this machine.</p> <p>Press the start/stop button to proceed the next step.</p>	<p>LCD displays "SC 11of".</p> 	
12) THREAD CUTTER MOTOR, THREAD CUTTER SOLENOID	<p>Not applicable for this machine.</p> <p>Press the start/stop button to proceed the next step.</p>	<p>LCD displays "SC 12--".</p> 	

SELF-DIAGNOSTIC TEST

STEP AND ITEMS TO CHECK	PROCEDURE	CORRECT CONDITION	DEFECTIVE CONDITION
<p>13) EEPROM</p>	<p>LCD displays "OK" or "NG", depending on the EEPROM condition.</p> <p>If the result is correct condition, press the start/stop button to proceed the next step.</p> <p>If the result is defective condition, press the reverse stitch button to proceed the next step.</p>	<p>LCD displays "OK" when the EEPROM is correct condition.</p>  <p>LCD displays "NG" when the EEPROM is defective condition.</p> 	<p>LCD displays "NG".</p> <p>-REMEDY- Replace the circuit board A.</p>

SELF-DIAGNOSTIC TEST

Buzzer sounds after few seconds when the self-diagnostic test has been finished. The test result has been determined.

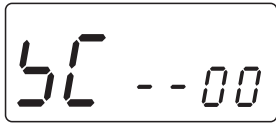

CORRECT:
Buzzer sounds and LCD displays "00"



DEFECTIVE:
Caution buzzer sounds and LCD displays the defective part number. Refer to pages 19-22 and fix the defective part. Each time you press the start/stop button, the defective part number(s) will be displayed.

The defective part number.
See pages 19-22 "Steps and items" section.

Press the reverse stitch button to return to 01.
Turn the power switch off when the self-diagnostic test is finished.

TO DISPLAY THE VERSION OF THE PROGRAM

1. Turn the power switch on while simultaneously pressing auto-lock button and needle up/down button.
2. The LCD display will indicate "01".
3. Press the value set key twice to display the "03".
4. Press the start/stop button to display the version of the program.
5. Each time you press the start/stop button, the version number will be partially displayed in sequence. Example: 811-1-1.00-001

REPLACING THE ELECTRONIC COMPONENTS

PRINTED CIRCUIT BOARD A CONNECTION

NOTE:

Do not disconnect the connectors by pulling on cord.
To disconnect, grasp the connector, not the cord.

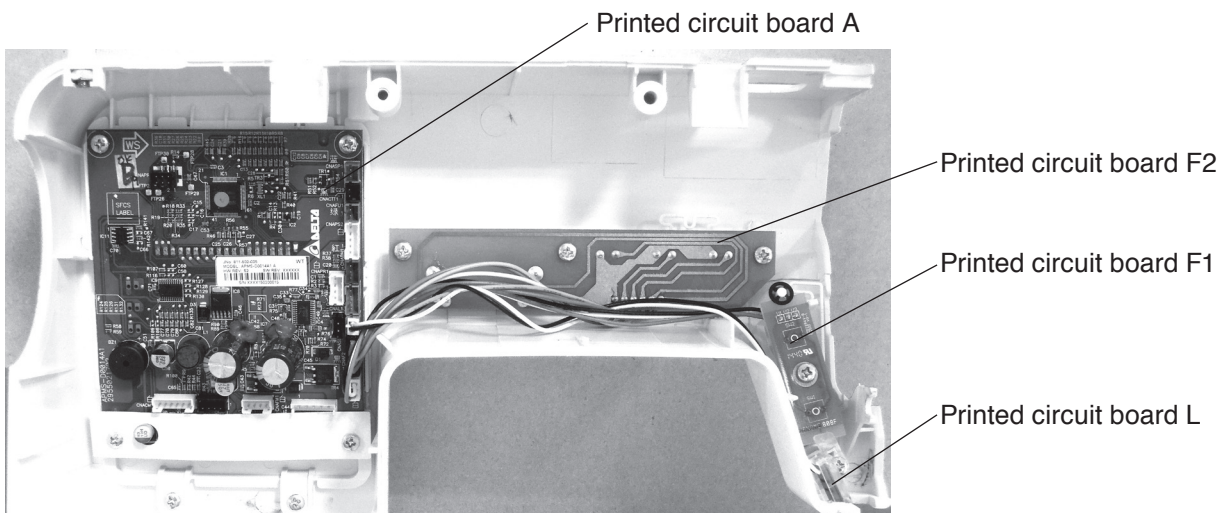
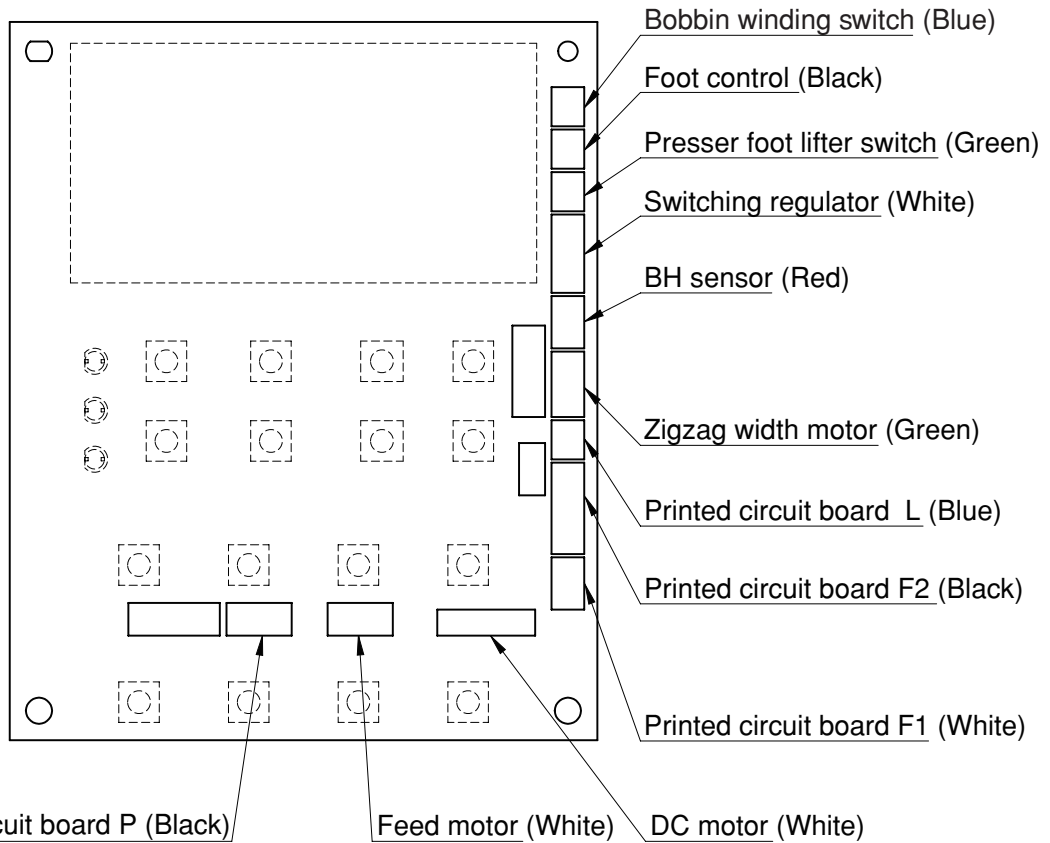

REPLACING THE ELECTRONIC COMPONENTS

PRINTED CIRCUIT BOARD A

TO REMOVE:

1. Remove the front cover. (See page 6.)
2. Pull out connectors from the printed circuit board A.
3. Remove the screws (4 pcs.) and the printed circuit board A.

TO ATTACH:

1. Follow the above procedures in reverse.

NOTE:

Do not disconnect the connectors by pulling on cord.
To disconnect, grasp the connector, not the cord.

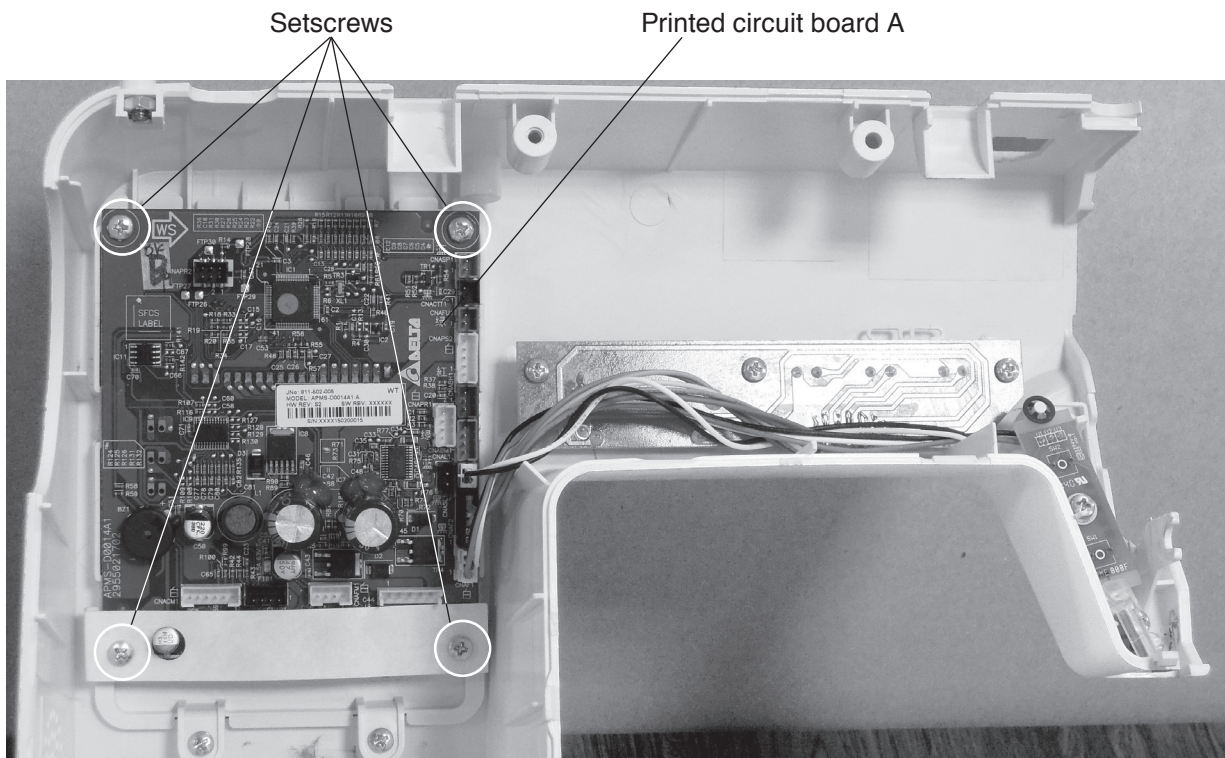

REPLACING THE ELECTRONIC COMPONENTS

PRINTED CIRCUIT BOARD F2

TO REMOVE:

1. Remove the front cover. (See page 6.)
2. Pull out connectors from the printed circuit board A.
3. Remove the screws (3 pcs.) and the printed circuit board F2.

TO ATTACH:

1. Follow the above procedures in reverse.

NOTE:

Do not disconnect the connectors by pulling on cord.
To disconnect, grasp the connector, not the cord.

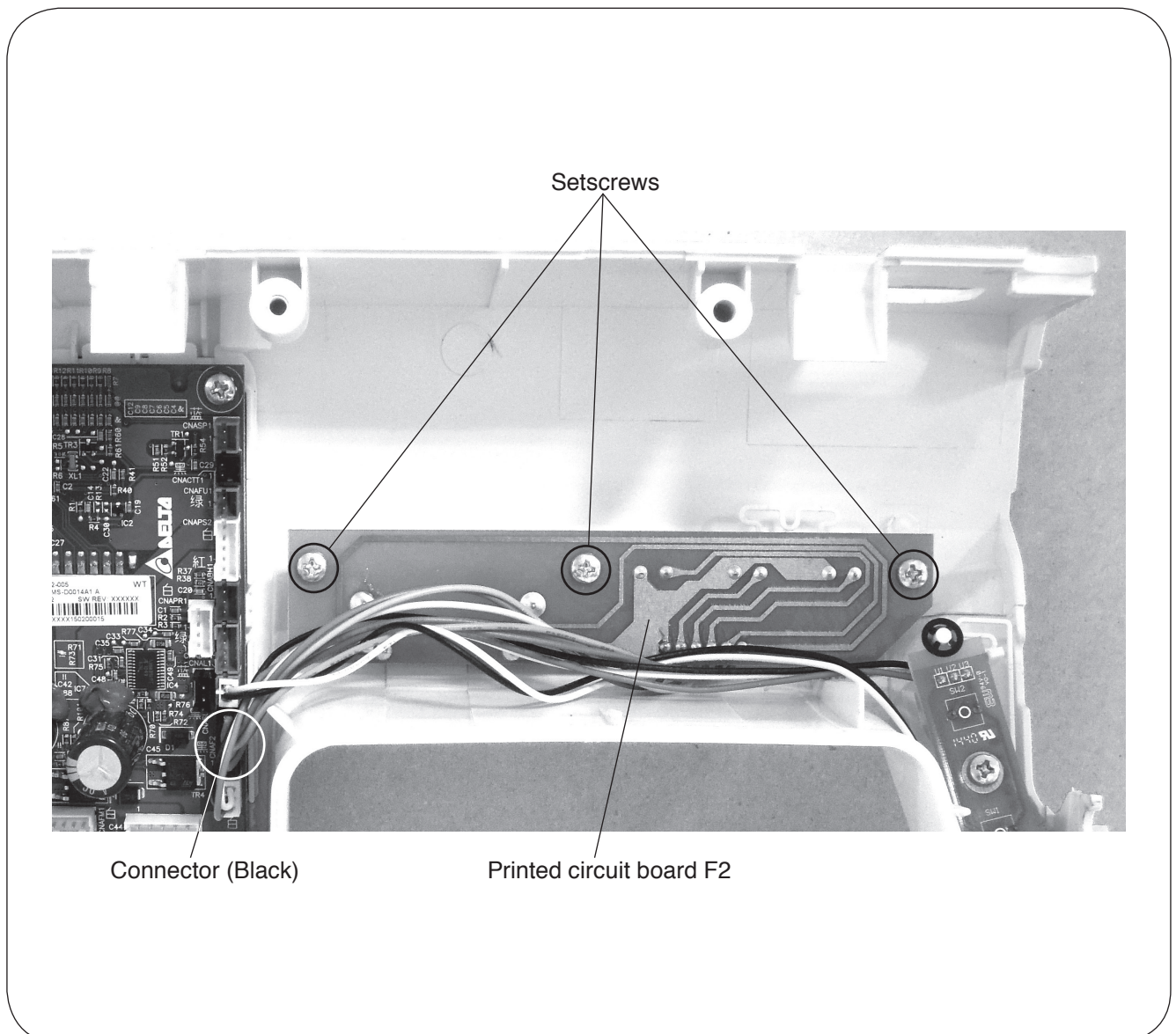

REPLACING THE ELECTRONIC COMPONENTS

PRINTED CIRCUIT BOARD F1

TO REMOVE:

1. Remove the front cover. (See page 6.)
2. Pull out connectors from the printed circuit board A.
3. Remove the screws (2 pcs.) and LED cover.
4. Remove the printed circuit board F2.

TO ATTACH:

1. Follow the above procedures in reverse.

NOTE:

Do not disconnect the connectors by pulling on cord.
To disconnect, grasp the connector, not the cord.

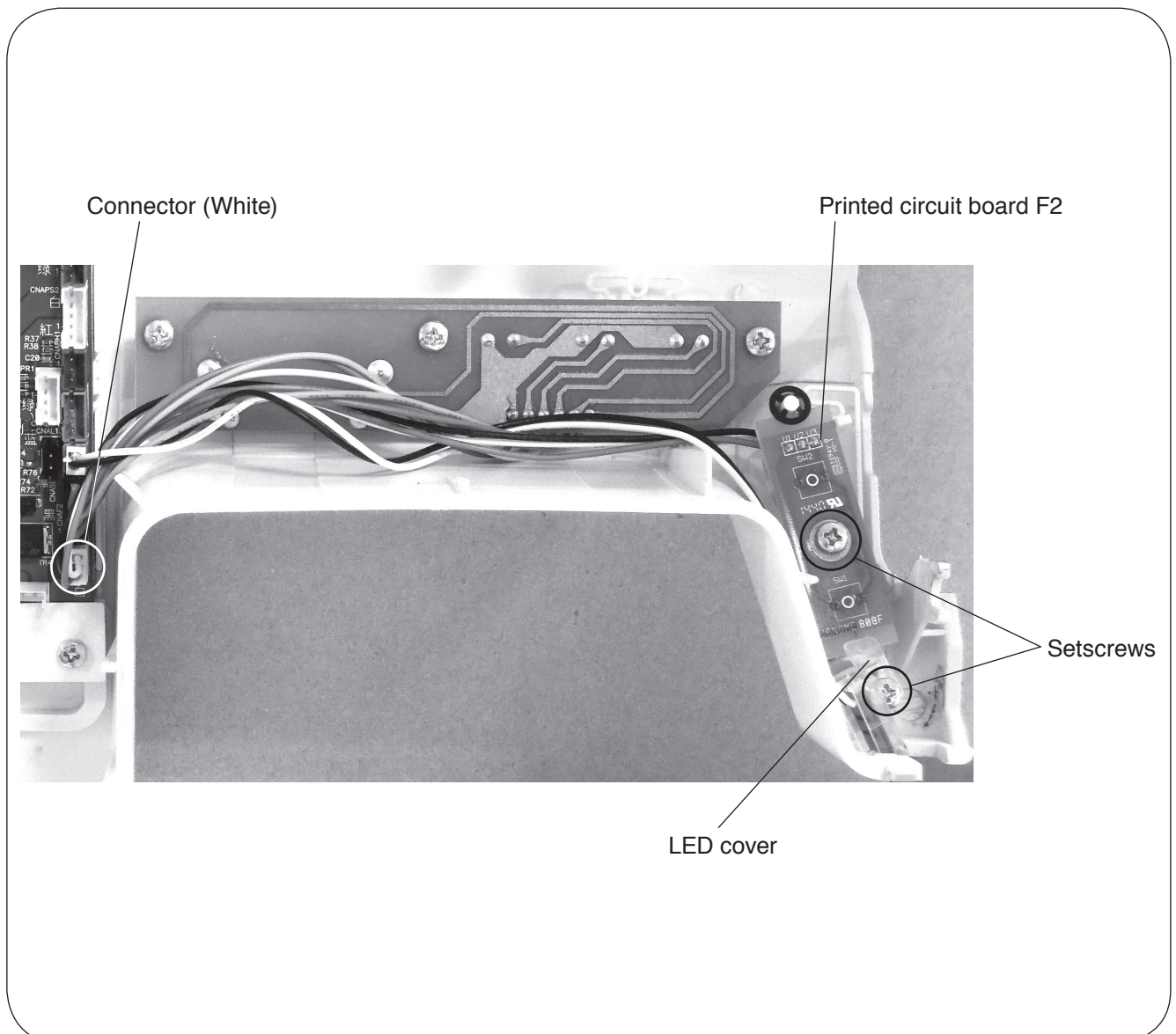

REPLACING THE ELECTRONIC COMPONENTS

PRINTED CIRCUIT BOARD L

TO REMOVE:

1. Remove the front cover. (See page 6.)
2. Pull out connectors from the printed circuit board A.
3. Remove the screw and LED cover.
4. Remove the printed circuit board L.

TO ATTACH:

1. Follow the above procedures in reverse.

NOTE:

Do not disconnect the connectors by pulling on cord.
To disconnect, grasp the connector, not the cord.

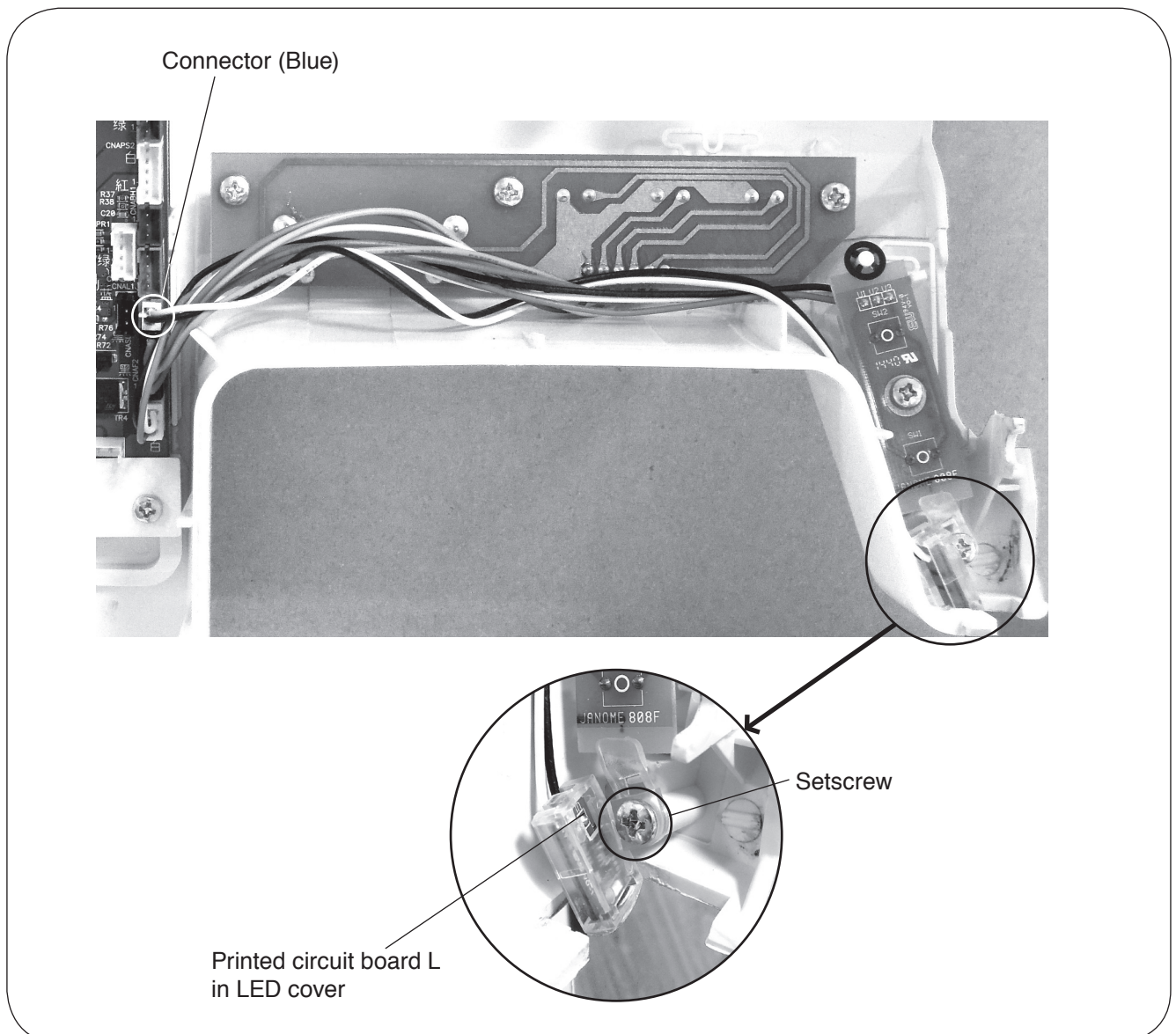

REPLACING THE ELECTRONIC COMPONENTS

DRIVING MOTOR (DC MOTOR)

TO REMOVE:

1. Remove the front cover. (See page 6.)
2. Remove the setscrews ① (2 pcs.), setscrew ② (1 pcs.), the driving motor and the belt.

TO ATTACH:

1. Install the driving motor and the motor belt. Tighten them with setscrews ① (2 pcs.) lightly.
2. Move the motor up or down to adjust the motor belt tension.
The belt should deflect 5 mm when applying 200 grams of load to the middle of the belt.
Tighten the setscrews ① (2 pcs.) firmly.
3. Secure the cables using the nylon clip and tighten the setscrew ② .
4. Attach the front cover.

Nylon clip

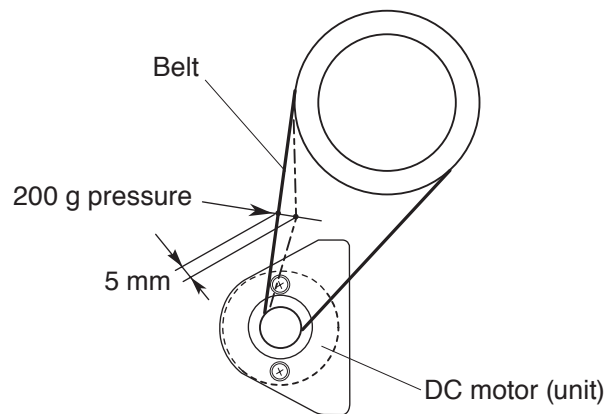
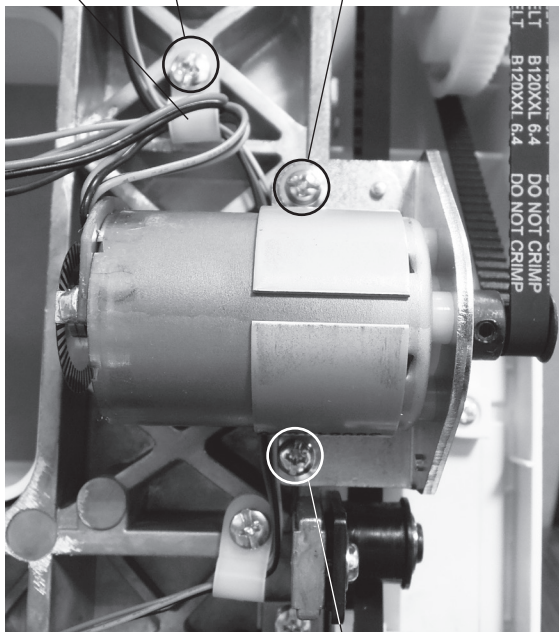

REPLACING THE ELECTRONIC COMPONENTS

SWITCHING REGULATOR UNIT

TO REMOVE:

1. Remove the front cover and the rear cover. (See pages 6 and 7.)
2. Remove the setscrews ① (3 pcs.) and the switching regulator.
3. Remove the setscrews ② (4 pcs.).

TO ATTACH:

4. Follow the above procedures in reverse.

Switching regulator

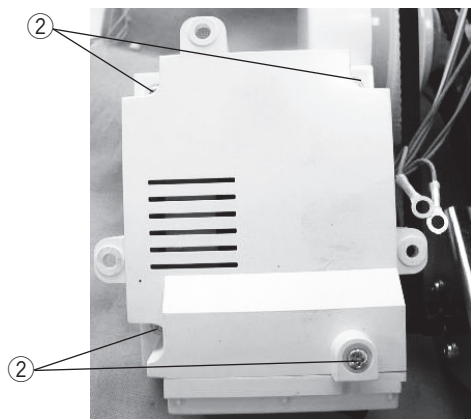
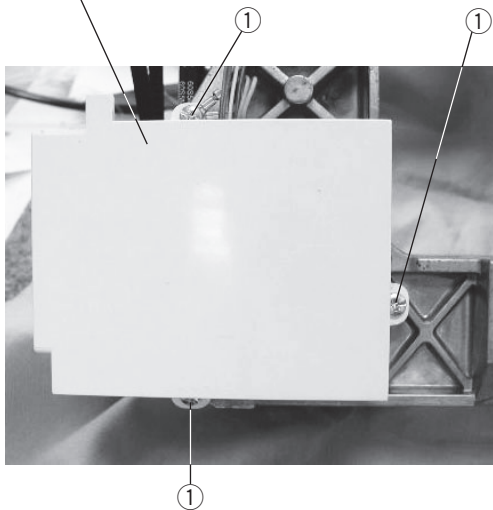

PARTS LIST

PARTS LIST

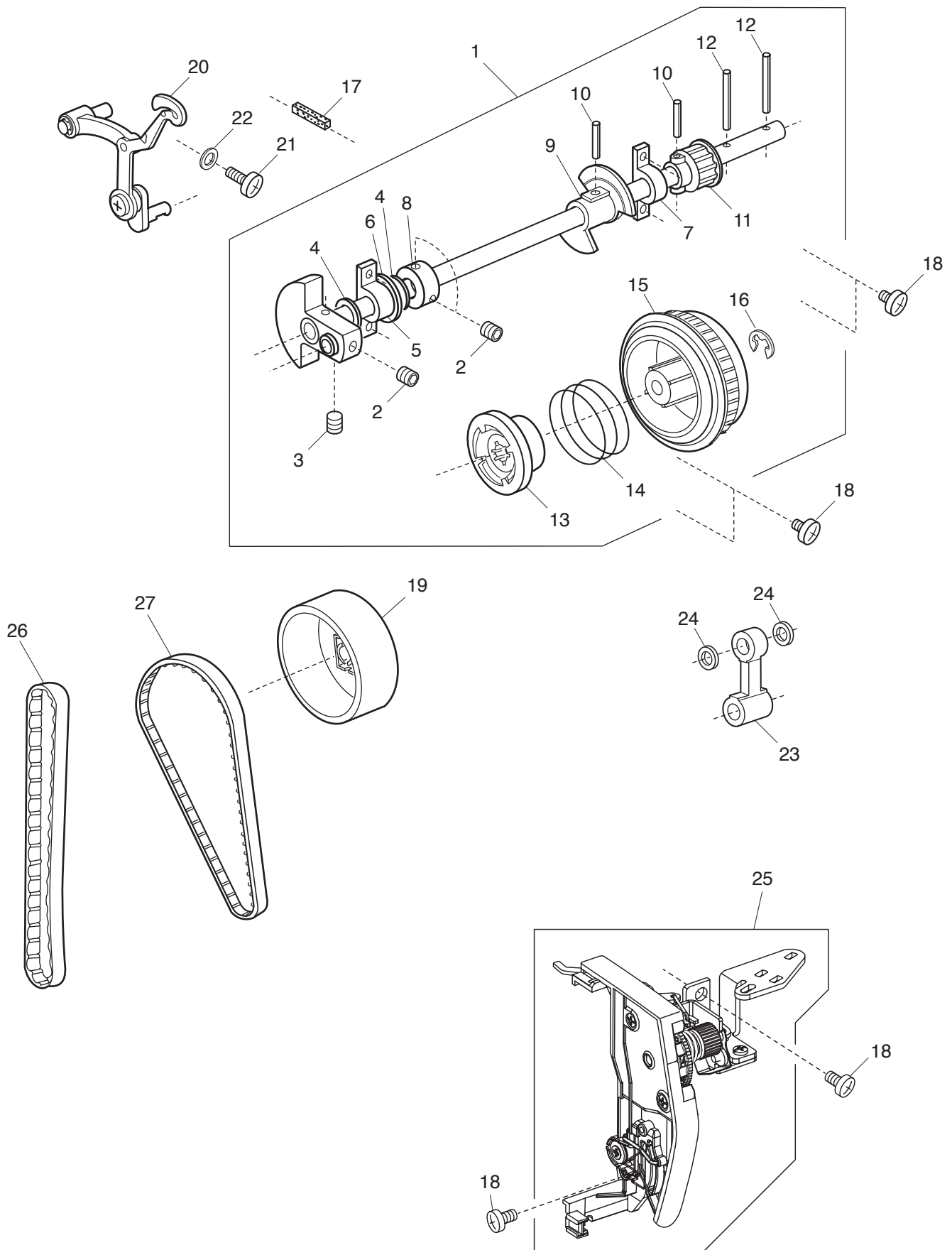

PARTS LIST

KEY NO.	PARTS NO.	DESCRIPTION
1	808601005	Upper shaft (unit)
2	000111201	Hexagonal socket screw 4x4
3	000112800	Hexagonal socket screw 4x6
4	000036201	Washer FT80
5	508120006	Shaft fixing metal
6	823110009	Felt
7	508054101	Shaft fixing metal
8	820166001	Lower shaft ring
9	808003001	Upper shaft shielding plate
10	000004200	Spring pin 3x18
11	508021006	Upper shaft gear
12	000024206	Spring pin 3x30
13	502064003	Clutch ring
14	661024007	Clutch spring
15	508055009	Belt wheel
16	000002806	Snap ring E-6
17	650040005	Felt
18	000081005	Setscrew 4x8
19	508056000	Handwheel
20	808648004	Thread take-up lever (unit)
21	000103509	Setscrew 4x10
22	000072302	Washer 4
23	808005003	Needle bar crank rod
24	000036005	Washer FT60
25	811511306	Thread tension (unit)
26	808037004	Syncro belt S5M
27	808021005	Timing belt 120

PARTS LIST

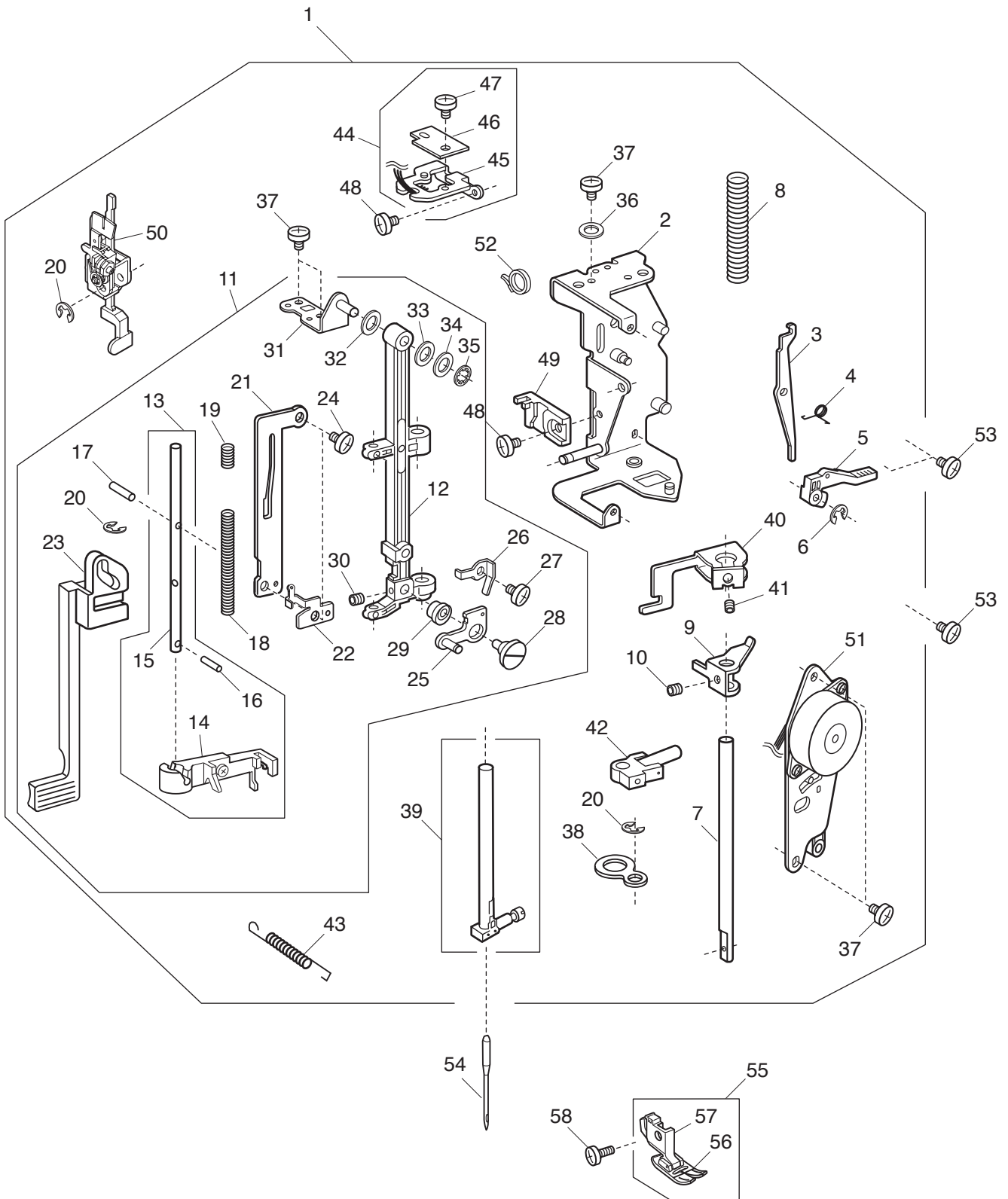

PARTS LIST

KEY NO.	PARTS NO.	DESCRIPTION
1	808602615	Presser bar base plate (unit)
2	808006004	Presser bar base plate
3	808007005	Thread tension release lever
4	503041007	Thread tension release spring
5	502024001	Presser foot lifter
6	000001609	Snap ring E-5
7	508002104	Presser bar
8	508038006	Presser bar spring
9	508039007	Presser bar supporter
10	000111500	Hexagonal socket screw 4x8
11	808603100	Needle bar supporter (unit)
12	808008006	Needle bar supporter
13	842637028	Threader shaft (unit)
14	846588014	Threader plate (unit)
15	840036025	Threader shaft
16	000003508	Spring pin 2x8
17	000125105	Guide pin E-2x16-CH
18	842090001	Threader shaft spring
19	842096007	Threader lever spring
20	000002105	Snap ring E-3
21	842091002	Threader guide plate
22	844036027	Threader lever plate
23	842092003	Threader lever
24	000078319	Setscrew 3x6
25	808015006	Zigzag width rod
26	827088009	Zigzag width rod spring
27	820373003	Setscrew 2x3
28	678084007	Eccentric pin
29	808074003	Washer
30	000111902	Hexagonal socket screw 3x4
31	808009007	Supporter adjusting plate
32	000036500	Washer FT60
33	673022002	Spring washer
34	000070609	Washer 6
35	000013903	Snap ring CS-5
36	000072003	Washer 5
37	000101404	Setscrew 4x6
38	808010001	Supporter guide plate
39	508607105	Needle bar (unit)
40	808011002	Threader position set plate
41	000177205	Hexagonal socket screw 3x6
42	508509003	Needle bar connecting stud (unit)
43	844038018	Needle bar supporter spring
44	808606000	Buttonhole sensor (unit)
45	845002005	Sensor set plate
46	843502602	Printed circuit board E1 (unit)
47	000101105	Setscrew 3x4
48	000103808	Setscrew 3x5
49	830057021	Buttonhole lever guide
50	808673008	Buttonhole lever (unit)
51	808605607	Zigzag width motor (unit)
52	000053008	Cord binder
53	000081005	Setscrew 4x8
54	102408089	Needle
55	660509008	Presser foot (unit)
56	832523007	Zigzag foot
57	660806008	Presser foot holder
58	660106001	Setscrew

PARTS LIST

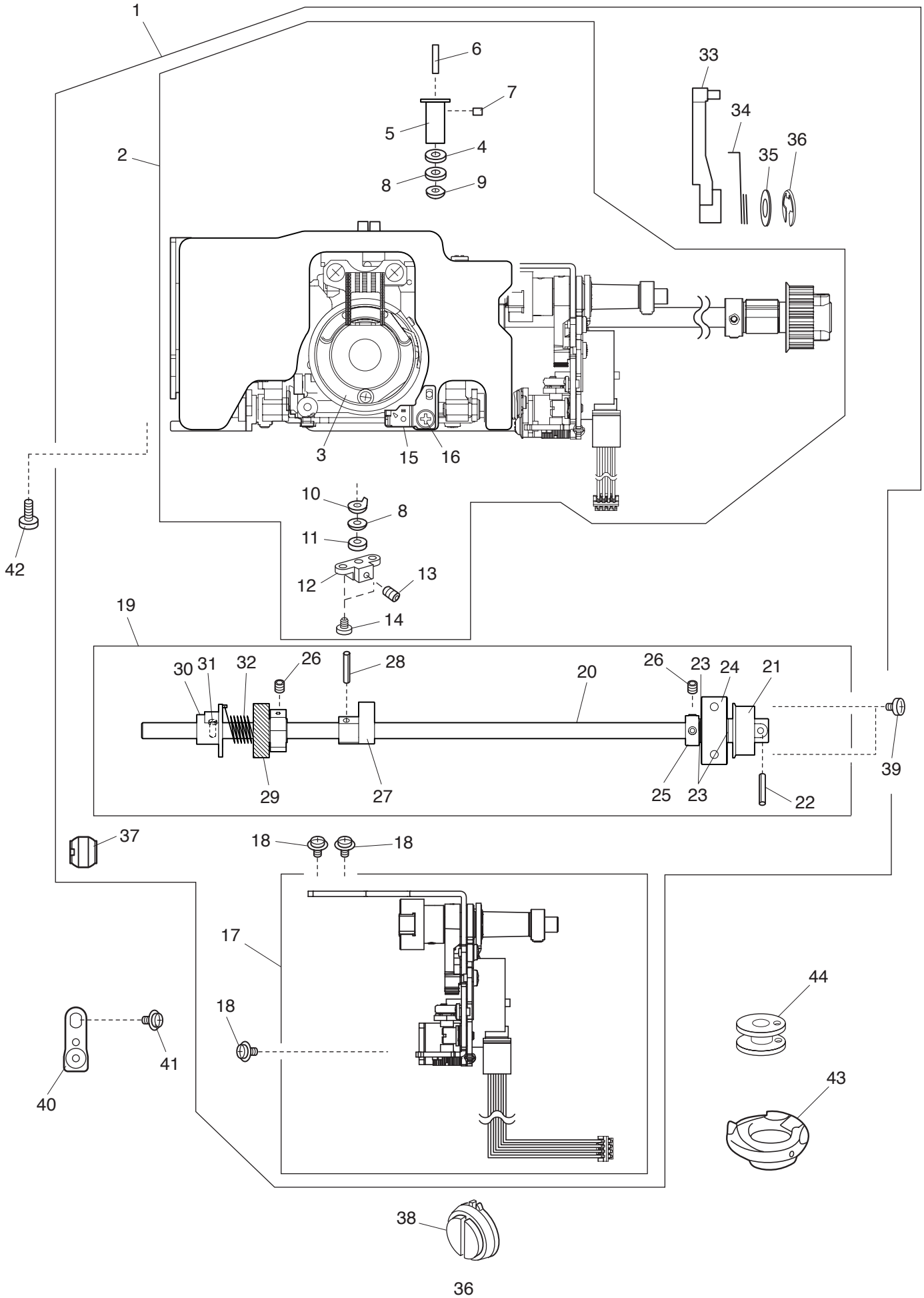

PARTS LIST

KEY NO.	PARTS NO.	DESCRIPTION
1	811607001	Hook race (whole unit)
2	811608002	Hook race (unit)
3	660536004	Hook body (unit)
4	508118001	Washer
5	820123006	Hook race shaft
6	820124007	Hook shaft oil wick (1)
7	820125008	Hook shaft oil wick (2)
8	000038409	Washer
9	508139008	Magnet set plate
10	627192001	Washer
11	625102008	Washer
12	508072002	Hook race shaft base
13	000111304	Hexagonal socket screw 5x5
14	000103705	Setscrew 4x5
15	627567104	Bobbin holder stopper (unit)
16	810220003	Setscrew
17	811611008	Feed regulator (unit)
18	000115205	Setscrew TP 4x6
19	811610007	Lower shaft (unit)
20	808027300	Lower shaft
21	508021006	Upper shaft gear
22	000004200	Spring pin 3x18
23	000038502	Washer
24	508054008	Shaft fixing metal
25	820166001	Lower shaft ring
26	000111201	Hexagonal socket screw 4x4
27	809014008	Feed cam
28	000005407	Spring pin 3x12
29	808137005	Lower shaft gear
30	753183025	Feed lifting cam
31	820161006	Feed lifting pin
32	686035008	Feed lifting cam spring
33	809013007	Feed fork
34	809015009	Feed fork spring
35	000071105	Washer 5
36	000002507	Snap ring E-4
37	732034003	Lower shaft rear bushing
38	809053009	Feed balancing dial 2
39	000081005	Setscrew 4x8
40	809042005	Lower shaft bushing set plate
41	000115607	Setscrew TP 4x8
42	000101703	Setscrew 4x12
43	627569106	Bobbin holder (unit)
44	102261103	Bobbin

PARTS LIST

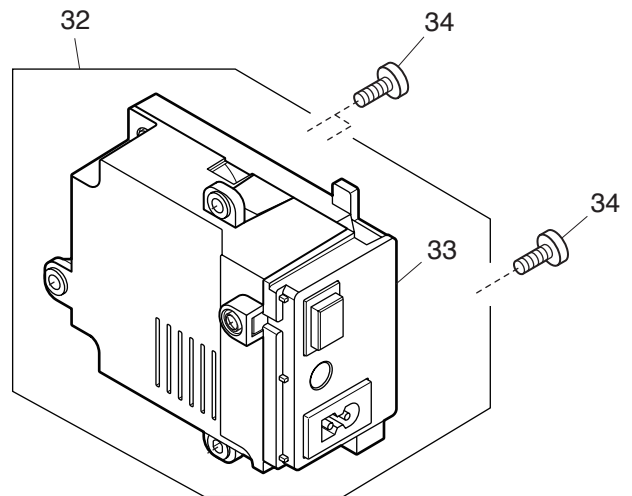
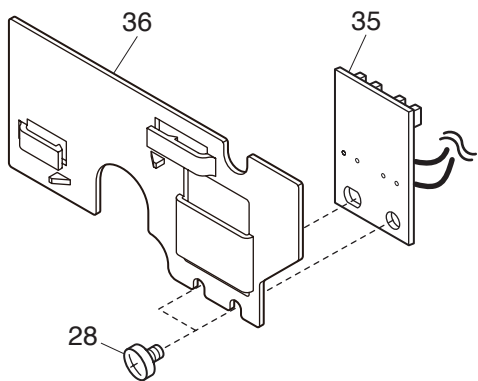
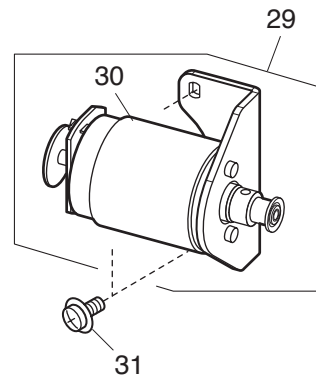
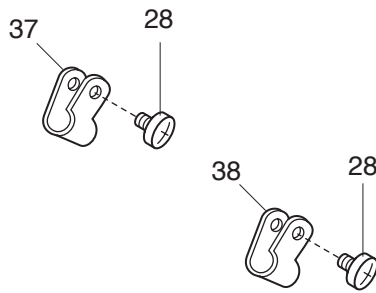
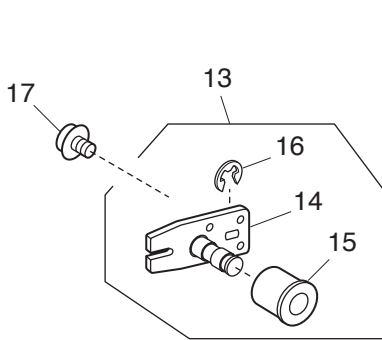
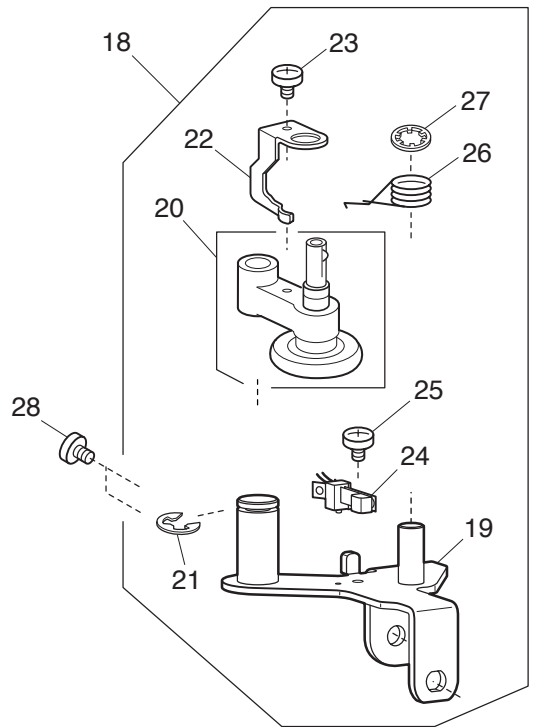
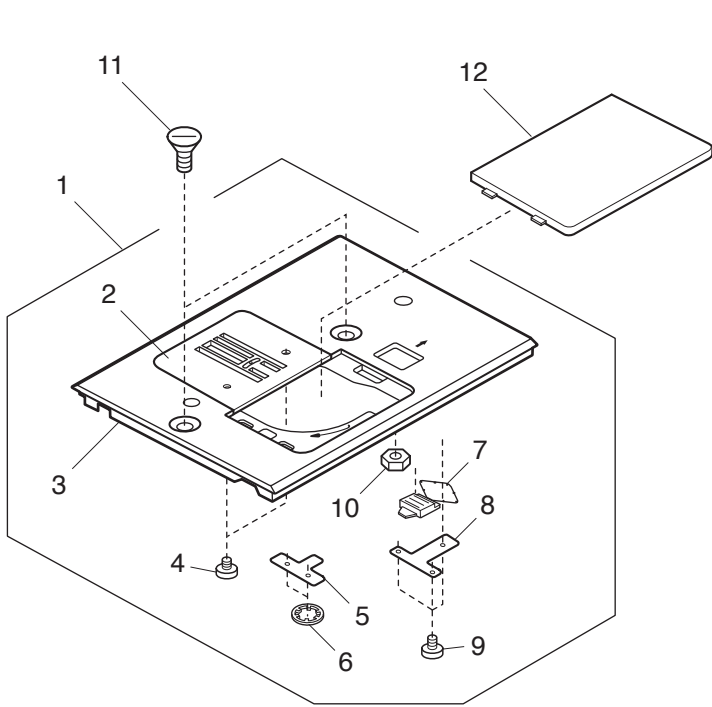

PARTS LIST

KEY NO.	PARTS NO.	DESCRIPTION
1	808626006	Needle plate (unit)
2	808067003	Needle plate
3	808068004	Support needle plate
4	000163703	Setscrew 2x3.5
5	502015009	Spring
6	000015503	Snap ring SC-2.4
7	502016000	Hook cover plate release button
8	502202005	Supporter plate
9	000130206	Setscrew 1.7x2.5 (B)
10	508116009	Nut
11	820390109	Setscrew
12	846271103	Hook cover plate
13	808614001	Idler (unit)
14	808038005	Idler set plate
15	625217100	Idler
16	000002806	Snap ring E-6
17	000115607	Setscrew TP 4x8
18	808615002	Bobbin winder (unit)
19	808039006	Bobbin winder set plate
20	508507001	Bobbin winder arm (unit)
21	000001609	Snap ring E-5
22	508111004	Clutch lever
23	000120203	Setscrew 3x8 (B)
24	856512100	Switch (unit)
25	000081706	Setscrew 2.5x5
26	808040000	Spring
27	000013903	Snap ring CS-5
28	000081005	Setscrew 4x8
29	808617004	DC motor (unit)
30	808502005	DC motor
31	000115700	Setscrew TP 4x10
32	808657408	Switching regulator (unit)
33	808525602	Switching regulator
34	000103509	Setscrew 4x10
35	808504007	Printed circuit board P (unit)
36	808181004	Cord guide
37	000188209	Nylon clip ACC-1.5
38	000188405	Nylon clip ACC-2

PARTS LIST

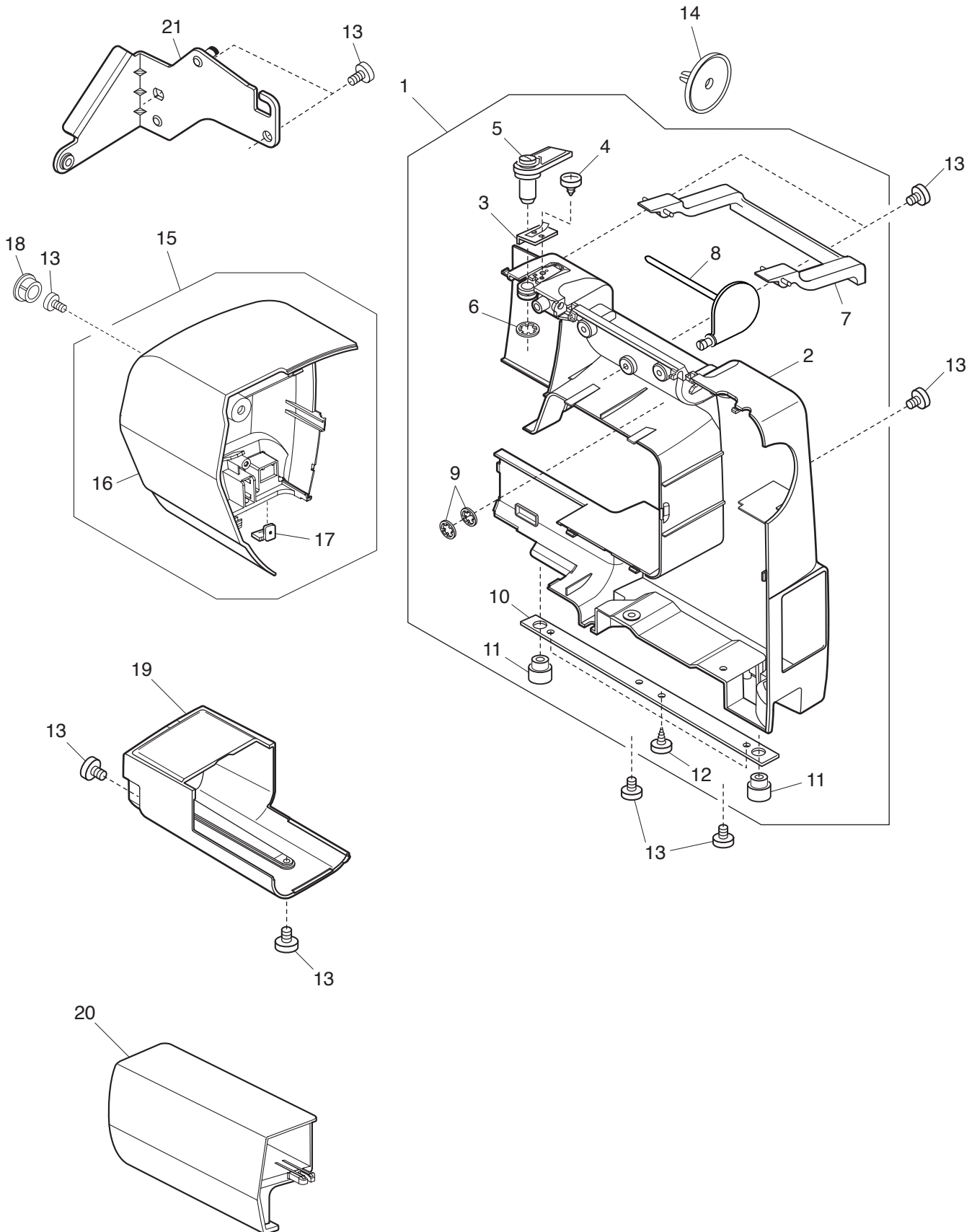

PARTS LIST

KEY NO.	PARTS NO.	DESCRIPTION
1	809604285	Rear cover (unit)
2	809025B06	Rear cover
3	827503108	Top cover thread guide (unit)
4	000162001	Setscrew 2.6x5 (B)
5	650503322	Thread guide (unit)
6	000014409	Snap ring CS-8
7	809026003	Carrying handle
8	809027004	Spool pin
9	000013800	Snap ring CS-6
10	809028005	Arm leg rear
11	735003002	Bed rubber cushion
12	000198604	Setscrew 4x14 (B)
13	000081005	Setscrew 4x8
14	822020503	Spool holder
15	811604031	Face plate (unit)
16	811012A10	Face plate
17	840602006	Thread cutter (unit)
18	653006101	Cap
19	808061007	Free arm cover
20	811013004	Extension table
21	811001009	Face plate set plate

PARTS LIST

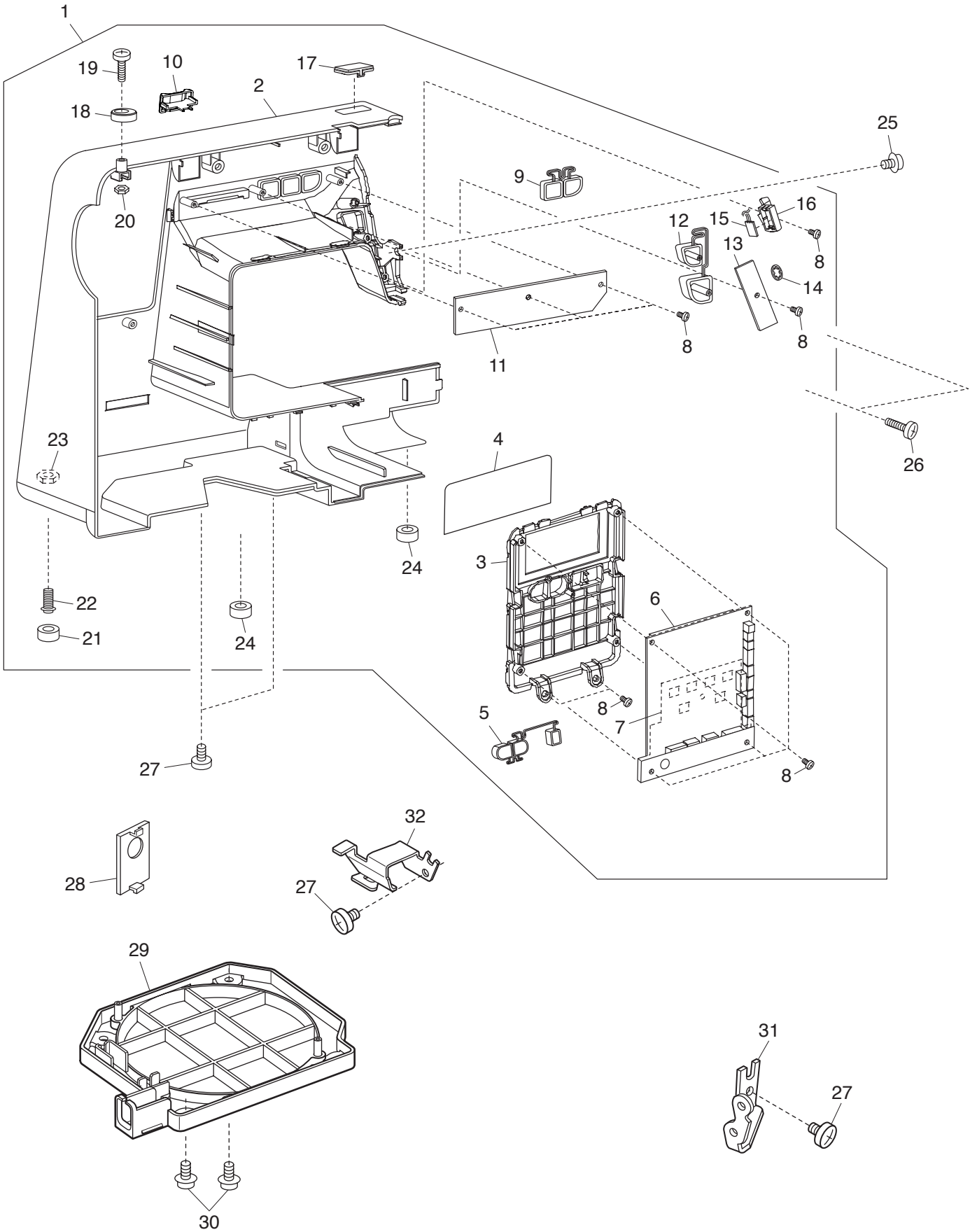

PARTS LIST

KEY NO.	PARTS NO.	DESCRIPTION
1	811603351	Front cover (unit)
2	811004A39	Front cover
3	811005A26	Ornamental panel 1
4	811006A19	Ornamental panel 2
5	811010A01	Button 2
6	811401003	Printed circuit board A (unit)
7	811021005	Flame retardant insulating paper
8	000120203	Setscrew 3x8 (B)
9	811007A01	Button 1
10	811008006	Slide volume
11	811503006	Printed circuit board F2 (unit)
12	811011A01	Button 3
13	808507103	Printed circuit board F (unit)
14	000014306	Snap ring CS-3
15	808506102	Printed circuit board L (unit)
16	808057000	Lamp holder
17	808103002	Front cover lid
18	735016307	Bobbin winder stopper
19	000101828	Setscrew 4x16
20	000061205	Nut 4-3-7
21	639005003	Rubber foot
22	000201405	Setscrew TP 4x16
23	000160102	Adjustable lock nut 4
24	739064003	Bed rubber cushion
25	000115205	Setscrew TP 4x6
26	000160401	Setscrew 4x16 (B)
27	000081005	Setscrew 4x8
28	809039009	Cap
29	808059301	Bed cover
30	000149312	Setscrew 3x8
31	639080002	Front cover set plate
32	808016007	Arm thread guide

PARTS LIST

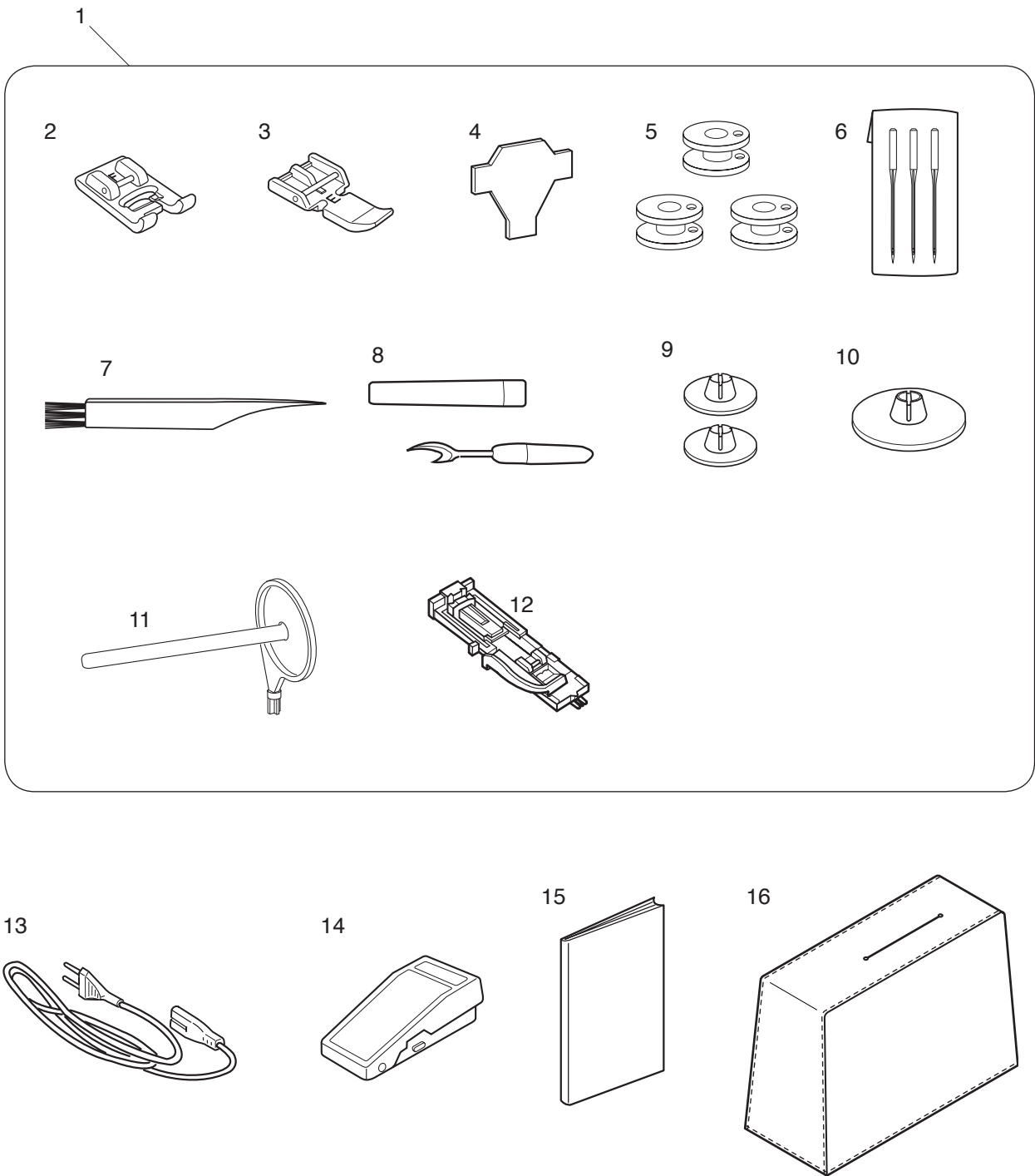

PARTS LIST

KEY NO.	PARTS NO.	DESCRIPTION
1	811870007	Standard accessories
2	822804118	Satin foot (F) (unit)
3	808852003	Zipper foot (E) (unit)
4	653802002	Screwdriver
5	102261103	Bobbin
6	639804000	Needle set (unit)
7	802424004	Lint brush
8	647808009	Seam ripper (Buttonhole opener)
9	822019509	Spool holder (small)
10	822020503	Spool holder (large)
11	809146000	Spool pin
12	753801004	Buttonhole foot (R) (unit)
13	830335004	Power supply cord
14	C-1036	Foot control
15	811800028	Instruction book
16	741811000	Cover